



Specification Catalog

5 Series
502W12

Geothermal heat pump
High Temp Hydronic Unit
7 ton

Table of Contents

Model Nomenclature	5
AHRI/ISO 13256-2 Performance Ratings	5
5 Series 502W12 Features.....	7
The 5 Series.....	8
Inside the 5 Series	9
Application Notes	14
Flow Rates.....	18
Water Quality	19
Dimensional Data.....	20
Physical Data.....	21
Electrical Data	21
Reference Calculations	21
Legend and Notes	21
Antifreeze Correction	22
Load and Source Pressure Drop.....	22
Performance Data	23
Wiring Schematics.....	25
Accessories and Options.....	30
Engineering Guide Specifications	33

5 Series

502W12 High Temp Hydronic Geothermal Heat Pump



WaterFurnace is proud to announce the latest in water source heat pumps by introducing the 5 Series 502W12 which is capable of producing water temperatures up to 150°F. Typically, water source heat pumps are limited to producing temperatures around 130°F which can make it difficult to retrofit an existing home that uses hot water for heat. The 5 Series 502W12 now provides the homeowner with an opportunity to retrofit their home with a state-of-the-art water source heat pump that allows them to save money while maintaining the comfort they expect from their conventional boiler system. The 5 Series 502W12 achieves its high efficiency while delivering hot water by utilizing low pressure R-134a refrigerant combined with high efficiency scroll compressors, braze plate heat exchangers, and the most reliable thermal expansion valves in the industry. R-134a has been the refrigerant of choice for years in the automotive industry when refrigerant R-12 was banned due to its high level of chlorine content. Unlike its predecessor, R-134a is a hydrofluorocarbon refrigerant that does not contain any chlorine yet has a Global Warming Potential (GWP) less than that of R-410A which is used in today's heat pump systems. The 5 Series 502W12 is certified to AHRI Standard 13256-2, safety listed with ETL, and Energy Star qualified by meeting stringent EPA requirements.

By offering part and full load operation, the 5 Series 502W12 also provides the homeowner with additional comfort by better matching the needs of the home due to changing outdoor conditions. Flexible capacity output of the 5 Series 502W12 combined with WaterFurnace's HydroZone™ controller, the homeowner can experience the ultimate in comfort and savings. The HydroZone controller will change the output of the 5 Series 502W12 depending on the outdoor temperature. When the outdoor temperature is mild, the HydroZone lowers the output of the heat pump and alternately raises the output as the temperature drops in the winter. This flexibility to vary output of the heat pump leaves the homeowner with optimal comfort and savings.

As a leader in the industry, WaterFurnace is dedicated to innovation, quality, and customer satisfaction. In fact, every unit built is exposed to a wide range of quality control procedures throughout the assembly process and is then subjected to a rigorous battery of computerized run tests to certify that it meets or exceeds performance standards for efficiency and safety, and will perform flawlessly at startup. As further affirmation of our quality standards, each unit carries our exclusive Quality Assurance emblem, signed by the final test technician.



WaterFurnace International's corporate headquarters and manufacturing facility is located in Fort Wayne, IN. A scenic three-acre pond located in front of the building serves as our geothermal heating and cooling source to comfort-condition our 110,000 square feet of manufacturing and office space. As a pioneer, and now a leader in the industry, the team of WaterFurnace engineers, customer support staff, and skilled assembly technicians is dedicated to providing the finest comfort systems available.

By choosing or specifying WaterFurnace 5 Series products, you can be assured that your customer is investing in the ultimate comfort system and peace of mind for many years to come.



All 5 Series 502W12 product is safety listed under UL1995 thru ETL and performance listed with AHRI in accordance with standard 13256-2. The 5 Series 502W12 is also Energy Star rated.

Model Nomenclature

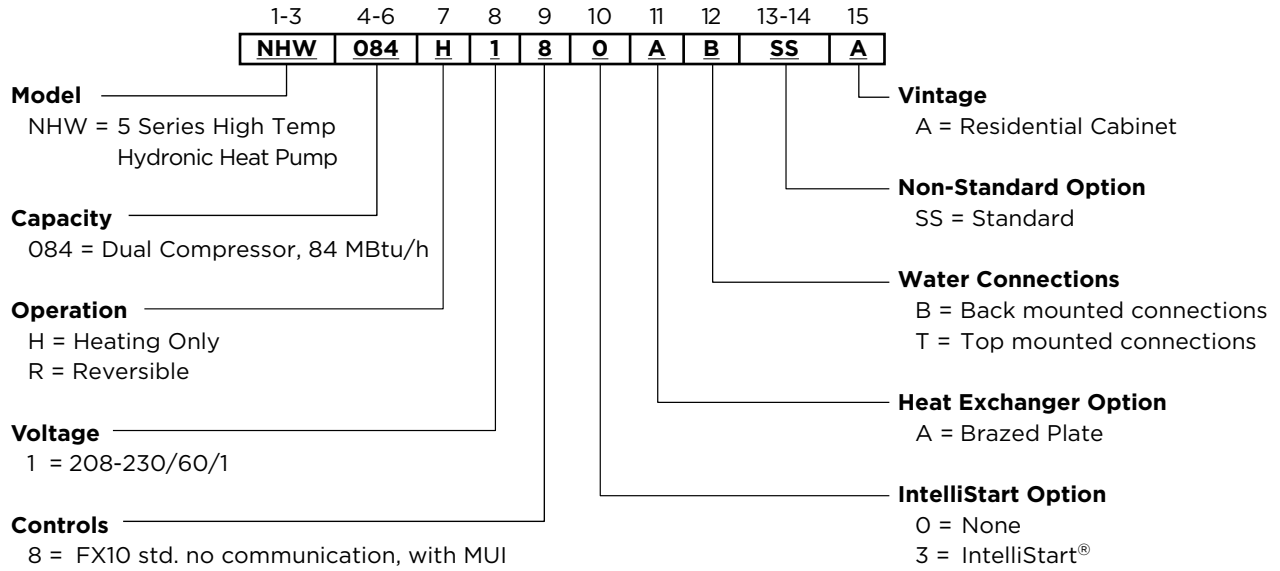

NOTE: MUI = Medium User Interface

AHRI/ISO 13256-2 Performance Ratings

English (IP) Units

Model	Capacity Modulation	Flow Rate		Water Loop Heat Pump				Ground Water Heat Pump				Ground Loop Heat Pump			
				Cooling EST 86°F ELT 53.6°F		Heating EST 68°F ELT 104°F		Cooling EST 59°F ELT 53.6°F		Heating EST 50°F ELT 104°F		Cooling Full EST 77°F Part EST 68°F ELT 53.6°F		Heating Full EST 32°F Part EST 41°F ELT 104°F	
		Sgpm	Lgpm	Capacity Btu/h	EER Btu/h per W	Capacity Btu/h	COP	Capacity Btu/h	EER Btu/h per W	Capacity Btu/h	COP	Capacity Btu/h	EER Btu/h per W	Capacity Btu/h	COP
084	Full	20	20	75,800	14.2	110,000	4.1	84,300	20.3	84,100	3.8	79,100	16.0	64,000	3.1
	Part	20	20	39,500	15.0	59,500	4.8	43,800	20.8	43,100	4.0	43,500	19.0	37,600	3.5

2/14/12

Energy Star Compliance Table

Model	Tier 3	
	Ground Water	Ground Loop
084	Yes	Yes

2/14/12

Energy Star Rating Criteria

In order for water-source heat pumps to be Energy Star rated they must meet or exceed the minimum efficiency requirements listed below. Please note there are 3 Tier levels that dictate minimum efficiency for water source heat pumps. Only one tier level is active at a given moment.

Tier 3: 1/1/2012 - No Effective End Date Published

	EER	COP
Closed loop water-to-air	17.1	3.6
Open loop water-to-air	21.1	4.1
Closed loop water-to-water	16.1	3.1
Open loop water-to-water	20.1	3.5



All 5 Series 502W12 product is safety listed under UL1995 thru ETL and performance listed with AHRI in accordance with standard 13256-2. The 5 Series 502W12 is also Energy Star rated.

AHRI/ISO 13256-2 Performance Ratings cont.

The performance standard AHRI/ASHRAE/ISO 13256-2 became effective January 1, 2000. This new standard has three major categories: Water Loop, Ground Water, and Ground Loop.

Unit of Measure: The Cooling COP

The cooling efficiency is measured in EER (US version measured in Btu/h per Watt. The Metric version is measured in a cooling COP (Watt per Watt) similar to the traditional COP measurement.

Pump Power Correction Calculation

Within each model, only one water flow rate is specified for all three groups and pumping Watts are calculated using the following formula. This additional power is added onto the existing power consumption.

- Pump power correction = $(\text{gpm} \times 0.0631) \times (\text{Press Drop} \times 2990) / 300$

Where 'gpm' is waterflow in gpm and 'Press Drop' is the pressure drop through the unit heat exchanger at rated water flow in feet of head.

ISO Capacity and Efficiency Calculations

The following equations illustrate cooling calculations:

- ISO Cooling Capacity = Cooling Capacity (Btu/h) x 3.412

- ISO EER Efficiency (W/W) = ISO Cooling Capacity (Btu/h) x 3.412 / [Power Input (Watts) + Pump Power Correction (Watt)]

The following equations illustrate heating calculations:

- ISO Heating Capacity = Heating Capacity (Btu/h) x 3.412

- ISO COP Efficiency (W/W) = ISO Heating Capacity (Btu/h) x 3.412 / [Power Input (Watts) + Pump Power Correction (Watt)]

Test Conditions

	ISO/AHRI 13256-2 WLHP	ISO/AHRI 13256-2 GWHP	ISO/AHRI 13256-2 GLHP
Cooling			
Liquid Entering Indoor Side - °F	53.6	53.6	53.6
<i>Standard Rating Test</i>			
Liquid Entering Heat Exchanger - °F	86	59	77
<i>Part-load Rating Test</i>			
Liquid Entering Heat Exchanger	86	59	68
Fluid Flow Rate	*	*	*
Heating			
Liquid Entering Indoor Side - °F	104	104	104
<i>Standard Rating Test</i>			
Liquid Entering Outdoor-side Heat Exchanger - °F	68	50	32
<i>Part-load Rating Test</i>			
Liquid Entering Outdoor-side Heat Exchanger	68	50	41
Fluid Flow Rate	*	*	*

NOTES: *Flow rate is specified by the manufacturer
 WLHP = Water Loop Heat Pump; GWHP = Ground Water Heat Pump;
 GLHP = Ground Loop Heat Pump

Conversions

Water Flow (lps) = $\text{gpm} \times 0.0631$

Press Drop (Pascals) = $\text{Press Drop (ft hd)} \times 2990$

5 Series 502W12 Features

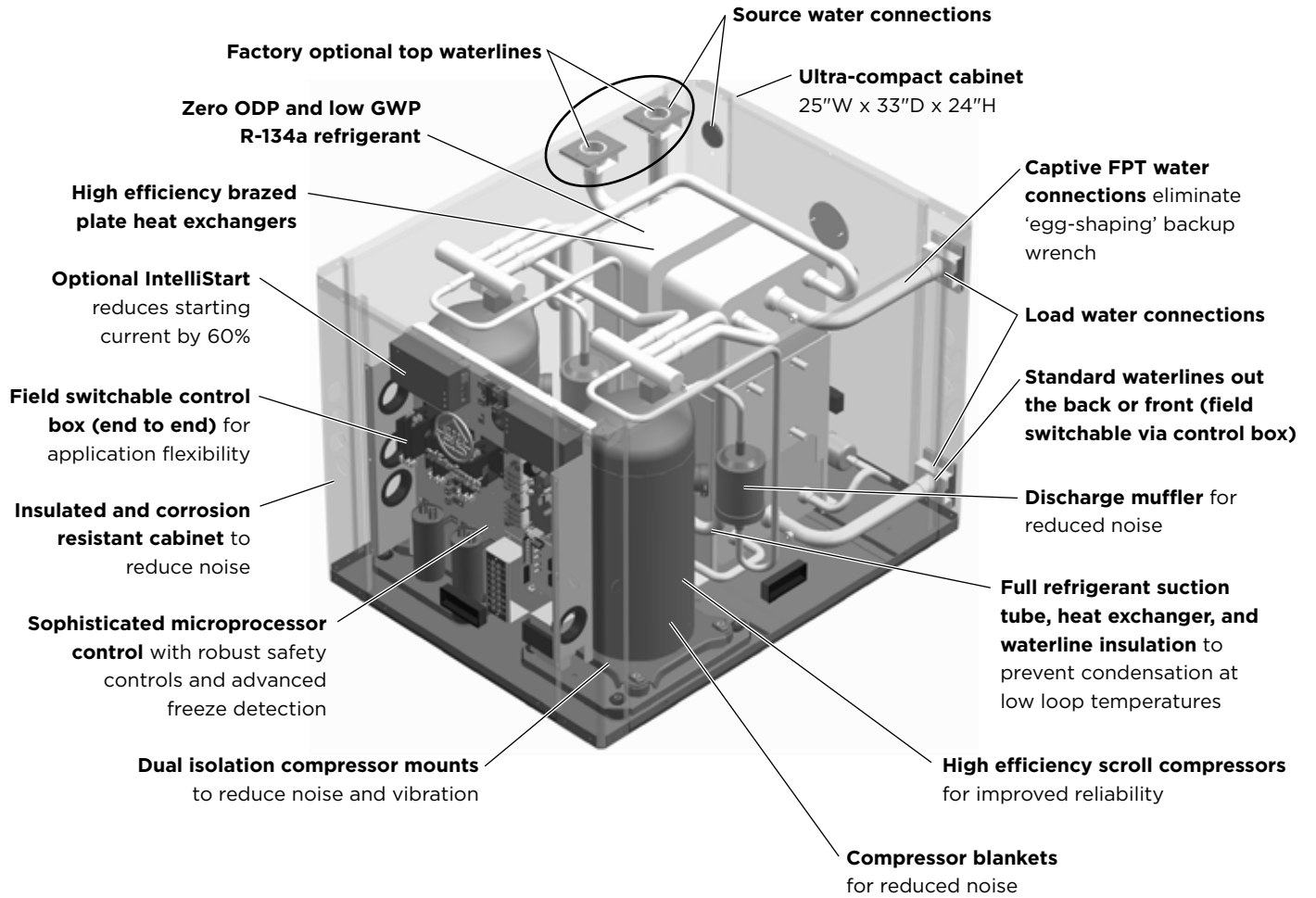

The 5 Series

High Efficiency

The 5 Series represents some of our best efficiencies and features. It's advanced components offer a level of comfort and savings that are among the industry's best. Large oversized water to refrigerant heat exchangers and scroll compressors provide extremely efficient operation. This efficiency means the 5 Series requires less loop than any product on the market.

Standard Features

- Single phase
- Heavy gauge cabinet
- Quiet scroll compressors
- Two-dimension refrigerant piping vibration loops to isolate the compressor.
- All interior cabinet surfaces are insulated with 1/2 in. [12.7 mm] thick 1-1/2 lb [681 g] density, surface coated, acoustic type glass fiber insulation.
- Optional IntelliStart to reduce starting current
- Field switchable control box
- Advanced FX10 control
- Ultra-compact cabinet
- Optional top or back mounted water lines
- Discharge line muffler to reduce compressor noise

Super Quiet Option

- Multi-density laminate lined compressor blanket designed to suppress low frequency noise



Easy Maintenance and Service Advantages

- Removable compressor access panels
- Quick attach wiring harnesses are used throughout for fast servicing
- High and low pressure refrigerant service ports
- User interface for diagnostics and commissioning of FX controls

Factory Quality

- All refrigerant brazing is performed in a nitrogen purge environment
- Computer controlled deep vacuum and refrigerant charging system
- All joints are leak detected for maximum leak rate of less than 1/4 oz. per year
- Computer bar code equipped assembly line ensures all components are correct
- All units are computer run-tested with water to verify both function and performance



Inside the 5 Series

Refrigerant

5 Series products all feature zero ozone depletion and low global warming potential R-134a refrigerant.

Cabinet

All units are constructed of corrosion resistant galvanized sheet metal with silver metallic powder coat paint rated for more than 1000 hours of salt spray. Large lift-out access panels provide access to the compressor section from four sides. Back or top water connection option is available.

Compressors

High efficiency R-134a scroll compressors are used on every model. Scrolls provide both the highest efficiency available and great reliability.

Electrical Box

Unit controls feature quick connect wiring harnesses for easy servicing. Separate knockouts for low voltage, and two for power on two sides allow easy access to the control box. A large 75VA transformer assures adequate control's power for accessories. Flexible Johnson Controls FX10 microprocessor control is included, featuring several innovations. See Microprocessor Controls section for more information.

Water Connections

Flush mount FPT water connection fittings allow one wrench leak-free connections and do not require a backup wrench. Factory installed thermistors are used on all water lines and can be viewed through the microprocessor interface tool.

Thermostatic Expansion Valve

All 5 Series models utilize a balanced port bi-directional thermostatic expansion valve (TXV) for refrigerant metering. This allows precise refrigerant flow in a wide range of entering water variation (30 to 120°F [-1 to 49°C]) found in geothermal systems.



Water-to-Refrigerant Heat Exchanger

Large oversized stainless steel interlaced copper-brazed plate water-to-refrigerant heat exchangers provide unparalleled efficiency. The heat exchangers have common water circuits with isolated refrigerant circuits so that in part load operation, the full mass of the heat exchanger is utilized. All heat exchangers are pressure rated to 450 psi on both water side and refrigerant side. All heat exchangers, water lines, and suction lines



are insulated to prevent condensation during low temperature inlet water operation.

Discharge Mufflers

Discharge line mufflers are included to help quiet compressor discharge gas pulsations.



Service Connections and Serviceability

Two Schrader service ports are provided for each circuit on every unit. The suction side and discharge side ports are for field charging and servicing access. All valves are 7/16 in. SAE connections.

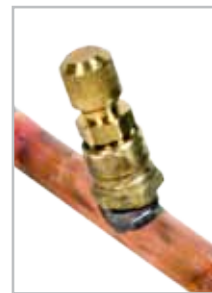

4-Way Reversing Valve

5 Series units feature a reliable all-brass pilot operated refrigerant reversing valve. The reversing valve operation is limited to change of mode by the control to enhance reliability.



IntelliStart®

The optional IntelliStart single phase soft starter will reduce the normal start current (LRA) by 60%. This allows the heat pump to go off-grid. Using IntelliStart also provides a substantial reduction in light flicker, reduces startup noise, and improves the compressor's start behavior.



Microprocessor Controls - FX10

FX10 Advanced Control Overview

- The Johnson Controls FX10 board is specifically designed for commercial heat pumps and provides control of the entire unit. The medium user interface (MUI) can be used to aid in diagnostics and unit setup and is standard on all units. A 16-pin low voltage terminal board provides terminals for common field connections. The FX10 Control provides:
 - Operational sequencing
 - High and low-pressure switch monitoring
 - General lockout
 - Advanced freeze detection temperature sensing
 - Lockout mode control
 - Emergency shutdown mode
 - Random start and short cycle protection

Short Cycle Protection

Allows a minimum compressor “off” time of four minutes and a minimum “on” time of two minutes.

Random Start

A delay of 1 to 120 seconds is generated after each power-up to prevent simultaneous startup of all units within a building after the release from an unoccupied cycle or power loss.

Emergency Shutdown

A field-applied dry contact can be used to place the control into emergency shutdown mode. During this mode, all outputs on the board are disabled.

Freeze Detection Temperature Limit

Field selectable for 15°F or 33°F (-9° or 0.56°C)

Installation Option

Standalone controlled by standard room thermostat

Accessory Outputs

Quantity 1. Cycled with the compressor. Field selectable for normally open (factory default) or normally closed through the building automation system or user interface.

User Interface

4 x 20 backlit LCD



Main FX10 Board

Display

One local display is standard on all units. Up to 2 displays, either 1 local and 1 remote, or 2 remote. (A 2-display configuration requires identical displays.) Local display can be up to 3 meters from the controller, power supply, and data communication. Remote display can be up to 300 meters from the controller. Remote display must be independently powered with data communication done via 3 pole shielded cable.

Control Timing and Fault Recognition Delays

Lead compressor “ON” delay	90 seconds
(not applicable for single compressor models)	
Minimum compressor “ON” time	2 minutes
(except for fault condition)	
Short cycle delay	5 minutes
Random start delay	0-120 seconds
High pressure fault	<1 second
Low pressure fault	30 seconds
Freeze detection fault	0-30 seconds
Low pressure fault bypass	2 minutes

Microprocessor Controls - FX10 cont.

FX10 Microprocessor



The FX10 control provides unparalleled capability in several areas including performance monitoring, energy management, and service diagnostics. The control will enumerate all fault conditions (HP, LP, LOC, and Freeze Detection) on a medium user interface (MUI). A Loss Of Charge fault can not be reset or bypassed until the problem has been corrected. A MUI is invaluable as a service tool for the service team.

The unit can be commanded to run by applying Y1, Y2, and B commands to the terminal board. The control board is wired with quick connect harnesses for easy field change out of a faulty control board. An alarm history can be viewed through the MUI and will be held in memory until the unit is power cycled.

The FX10 control has unused analog and digital inputs for field installed items such as water temperature or current status switches. A Medium User Interface (MUI) for control setup and advanced diagnostics is standard on all units.

Standard Features

- Anti Short Cycle
- High Pressure Protection
- Low Pressure Protection
- Advanced Freeze Protection
- Loss of Charge Detection
- Random Start
- Display for diagnostics
- Reset Lockout at disconnect
- 1 Accessory output
- Compressor Lead/Lag

Control and Safety Feature Details

Emergency Shutdown

The emergency shutdown mode can be activated by a command from a facility management system or a closed contact on BI-2. The default state for the emergency shutdown data point is off. When the emergency shutdown mode is activated, all outputs will be turned off immediately and will remain off until the emergency

shutdown mode is de-activated. The first time the compressor starts after the emergency shutdown mode has been de-activated, there will be a random start delay present.

Lockout Mode

Lockout mode can be activated by any of the following fault signals: refrigerant system high pressure, refrigerant system low pressure, or freeze detection. When any valid fault signal remains continuously active for the length of its recognition delay, the controller will go into fault retry mode, which will turn off both compressors. After the compressor short cycle delay, the compressors will attempt to operate once again. If three consecutive faults occur in 60 minutes, the unit will go into lockout mode, turning off the compressor(s), enabling the alarm output until the controller is reset. If the control faults due to the low pressure input being open during the pre-compressor startup check, the control will go into lockout mode immediately, disabling the compressors from starting and enabling the alarm output. The lockout condition can be reset by powering down the controller or by the holding the ESC and Return keys on the user interface for 5 seconds.

NOTE: See freeze detection section for more detail.



Freeze Danger Detection

The source and load heat exchangers are protected by a multi-sourced temperature logic strategy, primarily based on refrigerant temperature sensed as the refrigerant is about to enter the heat exchanger. Also the entering and leaving water temperatures are used as influencing factors.

Basic Freeze Detection Operation: “Comp1 or Comp2 Freeze” Alarm

This alarm can be triggered by one of two detection schemes.

Hard Limit Freeze Detection

If the refrigerant temperature drops below the freeze detection setpoint by 1.8°F, the associated compressor is locked out immediately regardless of any other factors and requires a manual reset. **NOTE: This Lockout produces a “Comp 1 or Comp 2 Freeze” error on the MUI display.**

Freeze Detection

The refrigerant temperature is compared to the freeze detection setpoint (15°F [antifreeze] or 33°F [water])

Microprocessor Controls - FX10 cont.

field selectable), and if the temperature falls below the setpoint for 30 continuous seconds, the associated compressor will be halted. This function becomes enabled after the first two minutes of compressor operation. Three such events in 60 minutes will trigger a compressor lockout that requires a manual reset.

NOTE: This Lockout produces a “Comp 1 or Comp 2 Freeze” error on the MUI display.

In addition to the above:

Entering Water Temperature Influence

If the entering water temperature of the evaporative heat exchanger is within 10°F of the freeze setpoint, the previously mentioned two minute delay will be eliminated. This allows the freeze detection to operate immediately when the compressor starts based on entering water temperature.

Leaving Water Temperature Influence

If the leaving water temperature of the evaporative heat exchanger is within 10°F of the freeze setpoint, the previously mentioned 30 second delay will begin to be proportionately reduced, ending at a 1 second delay when the leaving water temperature is 1.5°F above the freeze setpoint.

Dual Circuited Heat Exchanger Protection

A low temperature condition on either refrigerant circuit will prevent the start of both compressors. If the low temperature condition exists for 5 minutes when both compressors are off, a lockout is triggered for both compressors. However, if –for instance–both compressors are operating and circuit 1 experiences a refrigerant temperature below the freeze detection setpoint such that compressor 1 is halted, compressor 2 will not be halted as a result.

Advanced Freeze Detection Operation: “Pre Freeze” Alarm

Predictive freeze condition detection:

If the refrigerant temperature is within 7.2°F of the freeze detection setpoint, the predictive freeze detection algorithm is enabled, and if the logic determines that a freeze condition is likely to happen based on current conditions, the compressor of the involved refrigerant circuit is immediately stopped. Three (3) such events in 60 minutes will trigger a compressor lockout that requires a manual reset. In the absence of such a condition, the compressor is allowed to operate so that the refrigerant temperature may eventually be at the threshold of the freeze detection setpoint. **NOTE: This Lockout produces a “Pre Freeze” detection error on the MUI display.**

Capacity Limiting

If the leaving water temperature drops to 1.8°F above the freeze detection setpoint, the lead compressor is halted. When the leaving water temperature rises to 3.6°F above

the freeze detection setpoint, it will be allowed to resume operation. This limiting is allowed to repeat indefinitely with no lockout or indication on the display.

If the leaving water temperature drops to the freeze detection setpoint, the lag compressor is halted. When the leaving water temperature rises to 1.8°F above the freeze detection setpoint, it will be allowed to resume operation. This limiting is allowed to repeat indefinitely with no lockout or indication on the display.

High Pressure

The high-pressure switch shall be a normally closed (NC) switch that monitors the systems refrigerant pressure. If the input senses the high-pressure switch is open it must disable the compressor output immediately and count the fault. The compressor minimum on time does not apply if the high-pressure switch opens. The compressor will not restart until the compressor short cycle time delay has been satisfied.

Low Pressure

The low-pressure switch shall be a normally closed (NC) switch that monitors the systems refrigerant pressure. The input will be checked 15 seconds before compressor start up and then ignored for the first 2 minutes after the compressor output (BO-2) is enabled. If the switch is open continuously for 30 seconds during compressor operation the compressor output (BO-2) will be disabled. The compressor will not restart until the compressor short cycle time delay has been satisfied.

Alarm Outputs

The control has two alarm outputs, one for each compressor circuit. These 24VAC outputs are designated as LC1 (compressor 1) and LC2 (compressor2) on the low voltage terminal board.

Test Mode

By holding the ESC and down arrow keys on the MUI for 5 seconds will put the control into test mode. In test mode the random start delay and the compressor fixed on delay time will both be shortened to 5 seconds and the reversing valve will be allowed to cycle with out shutting down the compressor. If an MUI is connected to the control LED 8 will flash and the words “Test Mode Enabled” will be shown on the LCD display when the control is in test mode. Test mode will be disabled after a power cycle, 30 minute timeout, or by holding the ESC and Up arrow keys on the MUI.

Sequence of Operation

Power Fail Restart

When the controller is first powered up, the outputs will be disabled for a random start delay. The delay is provided to prevent simultaneous starting of multiple heat pumps. Once the timer expires, the controller will operate normally.

Microprocessor Controls - FX10 cont.

Random Start Delay

This delay will be used after every power failure, as well as the first time the compressor is started after the control exits the unoccupied mode or the emergency shutdown mode. The delay should not be less than 1 second and not longer than 120 seconds. If the control is in test mode the random start delay will be shortened to 5 seconds.

Lead Compressor Start Delay Time

The Lead Compressor Fixed On Delay Time will ensure that the lead compressor output is not enabled for 90 seconds after the control receives a call to start the compressor. This delay is adjustable from 30 – 300 seconds with a MUI. If the control is in test mode the Lead Compressor Start Delay Timer will be shortened to 5 seconds.

Lag Compressor Start Delay Time

The Lag Compressor Fixed On Delay Time will ensure that the lead compressor output is not enabled for 120 seconds after the control receives a call to start the compressor. If the control is in test mode the Lag Compressor Start Delay Timer will be shortened to 5 seconds.

Compressor Minimum On Delay

The compressor minimum on delay will ensure that the compressor output is enabled for a minimum of two (2) minutes each time the compressor output is enabled. This will apply in every instance except in the event the high pressure switch is tripped or emergency shutdown then the compressor output will be disabled immediately.

Compressor Minimum Off Delay Time

The compressor minimum time delay will ensure that the compressor output will not be enabled for a minimum of five (5) minutes after it is disabled. This allows for the system refrigerant pressures to equalize after the compressor is disabled.

Compressor Lead/Lag

Compressor lead/lag is a standard part of the FX10 control system. The unit is shipped from the factory with lead/lag enabled. Lead/lag can be deactivated through the unit mounted user interface. Lead/lag will always start the compressor with the least amount of run time and stop the compressor with the longest run time.

Heating Cycle

The control will run the unit in heating mode when there is no command on the O/B terminal on the terminal board.

Cooling Cycle

The control will run the unit in cooling mode when there is a command on the O/B terminal on the terminal board.

Inputs and Outputs Configuration

Field Selectable Options

Load and Source Freeze Detection Setpoint

The freeze detection setpoint input allows you to adjust the freeze detection setpoint for either the load or source sides of the heat pump. When the jumper is installed on BI-5 the load freeze detection setpoint is factory set for 30°F. When the jumper on BI-5 is removed the load freeze detection setpoint will be 15°F. When the jumper is installed on BI-4 the source freeze detection setpoint is factory set for 30°F. When the jumper on BI-4 is removed the source freeze detection setpoint will be 15°F. **NOTE: Piping circuit must be antifreeze protected to the set levels or the warranty will be voided.**

Accessory Output

The Accessory Output will be energized 90 seconds prior to the lead compressor output being energized. When both compressor outputs are turned off the accessory output will be deactivated immediately. This output is selectable for normally open or normally closed operation through the Medium User Interface or through the Building Automation System.

Control Accessories

- A99 Sensor
- MUI (LCD User interface) for diagnostics and commissioning
- MUIK3 - Panel Mount, Portable
- MUIK4 - Wall Mount

Application Notes

Heating with hot water is versatile because there are many ways of distributing the heat through the building. The options range from heavy cast iron radiators seen in older buildings to modern, baseboard-style convection radiation, and from invisible radiant floor heating to forced air systems using fan coil units.

The various distribution systems have all been used successfully with a geothermal heat pump system. When designing or retrofitting an existing hydronic heating system, however, the water temperature produced by the heat pump is a major consideration and should be compared to the system requirements.

The efficiency decreases as the temperature difference (ΔT) between the heat load (generally the earth loop) and the supply water (to the distribution system) increases. Figure 1 illustrates the effect of source and load temperatures on the system. The heating capacity of the heat pump also decreases as the temperature difference increases.

When using the various types of hydronic heat distribution systems, the temperature limits of the geothermal system must be considered. In new construction, the distribution system can easily be designed with the temperature limits in mind. In retrofits, care must be taken to address the operating temperature limits of the existing distribution system.

Figure 1: As the ΔT increases, the Coefficient of Performance (COP) decreases. When the system produces 130°F water from a 30°F earth loop, the ΔT is 100°F, and the COP is approximately 2.5. If the system is producing water at 90°F, the ΔT is 60°F and the COP rises to about 3.8, an increase of over 50%.

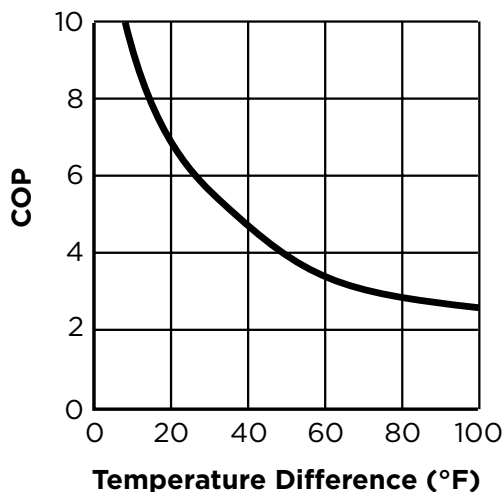

Baseboard Radiation

In existing systems, baseboard radiation is typically designed to operate with 160° to 240°F water or steam. Baseboard units are typically copper pipe with aluminum fins along the length of the pipe, as shown in Figure 2. A decorative cover is normally fitted over the fin tube.

The operation of a baseboard radiation system depends on setting up a convection current in the room: air is warmed by the fin tube, rises and is displaced by cool air.

The heating capacity of a baseboard system is a factor of the area of copper tube and fins exposed to the air and the temperature difference between the air and the fin tube. The velocity and volume of water flowing through the baseboard affects the temperature of the copper and fins. Baseboard units are normally rated in heat output/length of baseboard at a standard water temperature and flow. Manufacturers can provide charts which will give the capacities at temperatures and flows below the standard. Figure 3 shows approximate heating capacities for fin tube radiation using water from 110 to 150°F water.

Baseboards are available using two or three fin tubes tiered above one another in the same cabinet. With the additional surface area, the air can be heated enough to set up a convection current with water temperatures as low as 110° to 150°F (see Figure 3).

It is important to ensure that the heat output of the system is adequate to meet the heat loss of the room or building at the temperatures the geothermal system is capable of producing.

Baseboard radiation is limited to space heating. Cooling is typically provided by a separate, forced air distribution system.

Figure 2: Baseboard radiators are typically constructed of copper tube with closely spaced aluminum fins attached to provide more surface area to dissipate heat. Some of the factors affecting the amount of heat given off by fin tube radiators are the water temperature, water velocity, air temperature, and fin spacing and size.

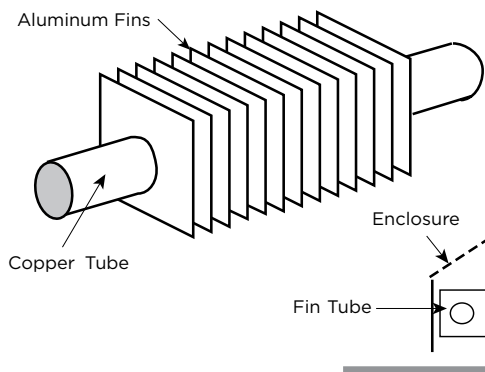

Application Notes cont.

The heating capacity (Btu/h per linear foot) of baseboard radiators drop as the water temperature is reduced. The heating capacity of most baseboard radiators is rated using 200°F water, 65°F air temperature. Listed in Figure 3 is the range of heating capacities of baseboard radiators at the standard temperatures and the range of capacities when the temperatures are reduced to the operating range of a heat pump system. Some of the factors that affect the capacity of a radiator are:

- Size of the fins - range from 2.75 in. x 3 in. to 4 in. x 4 in.
- Fin spacing - 24 to 48/foot
- Diameter of copper tube - range from .75 in. to 2 in.
- Fin material - aluminum or steel
- Configuration and height of the enclosure
- Height unit is mounted from the floor
- Water flow through the radiator

Generally, the smaller fins with fewer fins/foot will have lower heating capacity. Larger copper tube diameter and aluminum fins will have a higher capacity. Higher water flow will increase capacity. Adding a second fin tube to the same enclosure will increase the capacity by 50 to 60%. Adding two fin tubes will increase the capacity by 75 to 80%.

Figure 3: Heating output per linear foot (Btu/h)

Average Water Temp.	Entering Air Temperatures		
	55°F	65°F	70°F
110°F	190-380	160-320	150-300
120°F	240-480	205-410	195-390
130°F	295-590	265-532	245-490
140°F	355-710	335-650	300-600
150°F	420-830	415-780	360-720

Cast Iron Radiation

Retrofit applications for hydronic/geothermal heat pump systems are often required to work with existing cast iron radiators or their replacements (see Figure 4). Typically, cast iron radiator systems operate with water temperatures of 125° to 160°F.

The 5 Series 502W12 was specifically designed to meet these higher temperatures. Cast iron radiators can work with geothermal systems, provided the heat output of the radiators will meet the maximum heat loss of the building at the lower temperatures.

If the insulation of the building has been upgraded since the original installation, it is possible that the lower temperatures will be able to meet the reduced heat loss of the building.

Figure 4: Baseboard System

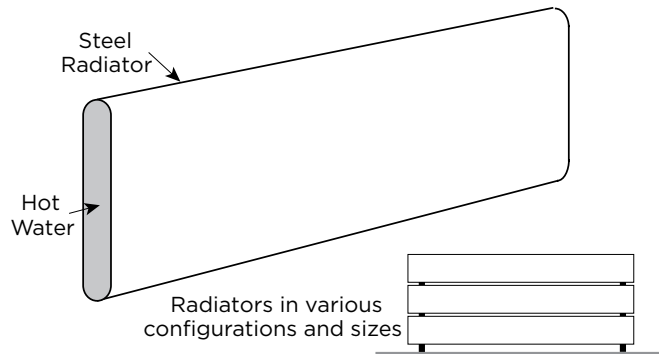

Radiant Floor Heating

Radiant floor heating has been the system of choice in many parts of Europe for some time. Manufacturers have developed tubing designed for installation in concrete floors and raised wood floors.

Floor heating systems have several benefits in residential, commercial and industrial heating applications. In a building with a radiant floor heating system, the entire floor acts as a heat source for the room. People feel comfortable with lower air temperatures if their feet are warm. Typically the space will feel comfortable with air temperatures as low as 65°F. Since the heat loss of a building is directly related to the temperature difference (ΔT) between the inside and outside, a lower ΔT means the heat loss is lower.

Air temperatures in a room with a forced air heating system tend to be warmer nearer to the ceiling than the floor (see Figure 5). The hot air rises and creates a greater pressure imbalance between the inside and outside. The infiltration increases, resulting in a higher heat loss. Air temperatures in a room with radiant floor heating tend to be warmer at the floor than the ceiling, helping to cut down on infiltration in the building. The energy savings in a building with radiant floor heating can range from 10 to 20%.

Figure 5: Temperature Comparison

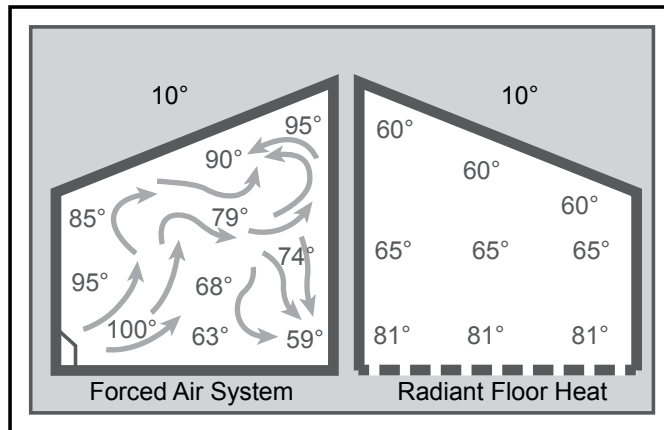

Application Notes cont.

A floor heat system can be designed to heat a building with water temperatures as low as 90°F.

Figure 1 shows how a geothermal system operates more efficiently with a lower ΔT between the source and the load. With only a 60°F temperature difference, a hydronic geothermal heat pump will operate at COPs, about 20% higher than a forced air geothermal system in the same installation.

Some of the factors affecting the heating capacity of a floor heating system are as follows:

- The type of finish flooring
- The spacing of the pipe
- The water flow through the pipe
- The temperature of the supply water
- The floor material (wood, concrete or poured Gypcrete™)
- Insulation value under the floor
- The piping layout

The spacing of the pipe in residential applications can vary from 4 in. to 12 in. If the spacing is too large, the temperature of the floor can vary noticeably. In industrial applications, variation in the floor temperature is not as important, and the spacing is related directly to the heat output required.

Radiant floor heating systems work well with geothermal heat pump systems. For efficient operation, the system must be designed with the lowest possible water temperatures.

There are some drawbacks with a radiant floor heating system. Air conditioning is only possible by adding a second system using forced air. This can add substantial cost to an installation where air conditioning is also needed. A separate air handling system is needed to clean the air or to introduce fresh air.

Industrial buildings, especially those with high ceilings and large overhead doors, have an advantage with a radiant floor heating system. Heat is stored in the concrete floor, and when a door is opened, the stored heat is immediately released to the space. The larger the ΔT between the air in the space and the floor, the quicker the floor releases its heat to the space.

Maintenance garages benefit from radiant floor heating systems. Cold vehicles brought into the garage are warmed from underneath. The snow melts off the vehicle and dries much more quickly than when heated from above.

Some pipe manufacturers include an oxygen diffusion barrier in the pipe to prevent oxygen diffusion through the pipe. Good system design and careful installation, however, will eliminate virtually all of the problems encountered with air in the system. Like earth loop design, it is important to design the system to facilitate flushing the air initially and ensuring that the flows can be balanced properly.

Fan Coil Units and Air Handlers

Fan coil units, air handlers, force flow units, etc. are all basically a hot water radiator or coil (usually copper piping with aluminum fins) with a fan or blower to move the air over the coil (see Figure 6). The term “fan coil units” typically applies to smaller units that are installed in the zone or area in which heating (or cooling) is needed. They are available in many different configurations, sizes and capacities. Fan coil units are designed to be connected to a ductwork system and can be used to replace a forced air furnace. Other units are designed for use without ductwork and are mounted in a suspended ceiling space with only a grill showing in place of a ceiling tile. Some can be mounted on a wall under a window, projecting 8 in. to 10 in. into the room or even flush to the wall surface, mounted between wall studs. Some are available with or without finished, decorative cabinets. For industrial applications, inexpensive “unit heaters” are available, with only a coil and an axial fan. Fan coil units and unit heaters are normally available with air handling capacities of 200 to 2,000 cfm.

The term “air handler” normally applies to larger units, mounted in mechanical rooms, mechanical crawl spaces or rooftops. They typically have an air handling capacity of over 2,000 cfm and are available for capacities of up to 50,000 cfm. Air handlers are typically built for a specific installation and are available with many different types of heating and cooling coils. They can include additional coils for heating make-up air, dehumidification and exhaust air heat recovery.

Fan coils and air handlers typically have one or two coils and a blower. Air is heated by hot water circulated through the hot water coil. Chilled water is circulated through the coil if air conditioning is needed. Blowers can be provided to fit various applications, with or without duct-work. Unit heaters typically use axial fans in applications where ductwork is not needed.

Fan coil units and air handlers are used in many different applications. They have been used to heat buildings using water temperatures as low as 90° to 100°F. New systems can be designed to operate very efficiently with a geothermal system.

Application Notes cont.

Figure 6: Fan Coils

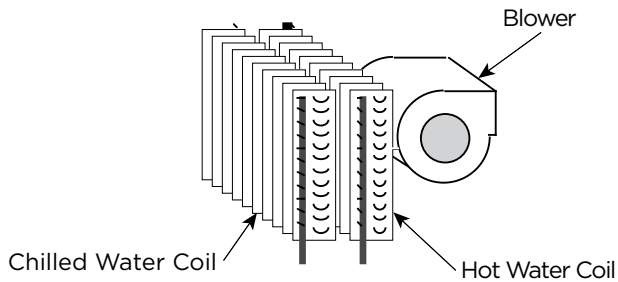

Cooling with a Hydronic System

Cooling a building with an existing radiant hydronic heating system can be a challenge. If baseboard, cast iron radiators or a radiant floor heating system is cooled lower than the dew point, condensation will form on the floor or drip off the radiators.

There is generally minimal or no ductwork for ventilation in existing buildings with radiant hydronic heat. Typically, cooling is provided with separate units where it is needed. This is often done using through-the-wall or window air conditioners, ductless split air conditioning units, or rooftop units.

A water-to-water heat pump system can provide water to ducted or unducted fan coil units. The system can provide chilled water to cool the building, as well as hot water for the heating system when needed.

A limited amount of cooling can be done by circulating chilled water through the piping in the floor. This can be effective in buildings with high solar loads or lighting loads, where much of the heat gain is radiant heat being absorbed by the floor. Cooling fresh air used for ventilation as it is brought into the building, using a chilled water coil, can sometimes provide the additional cooling needed. Care must be taken to avoid cooling the floor below the dew point because condensation may form on the floor.

Buildings with fan coil units and air handlers can generally be easily retrofitted for cooling. Often it is simply a matter of adding a cooling coil to the existing air handlers and fan coil units. Water-to-water heat pumps can provide hot water for the heating coils as well as chilled water for the air conditioning.

Controls

The control of a mechanical system determines how it functions. For the building to work efficiently and comfortably, the building owner or manager must understand what the system is doing and how to control it.

As Figure 1 shows, the efficiency of a heat pump is a factor of the difference in temperature between the source and the load. The heat loss or heat gain of a building varies with the weather and the use of the building. As the outdoor temperature decreases, the heat loss of the building increases. When the ventilation system is started up, the heating or cooling loads increase. As the occupancy increases, lighting or the solar gain increases, and the cooling load increases. At times the building may require virtually no heating or cooling.

With hydronic heating and cooling distribution equipment, whether it is baseboard radiation, fan coil units or radiant floor heating, the output of the equipment is directly related to the temperature and velocity of the water flowing through it. Baseboard radiation puts out approximately 50% less heat with 110°F water than with 130°F water. The same is true with fan coil units and radiant floor heating.

If a system is designed to meet the maximum heat loss of a building with 130°F water, it follows that if the heat loss is 50% lower when the outdoor temperature is higher and the building has high internal gains because of lighting and occupancy, the lower heat loss can be met with 110°F water. This greatly increases the COP of the heat pumps.

The same control strategy is equally effective in cooling. During peak loads, water chilled to 40°F may be needed; at other times 55°F water will provide adequate cooling. Significant increases in the EER can be achieved. Latent loads must always be considered when using warmer water.

Typical Application Piping

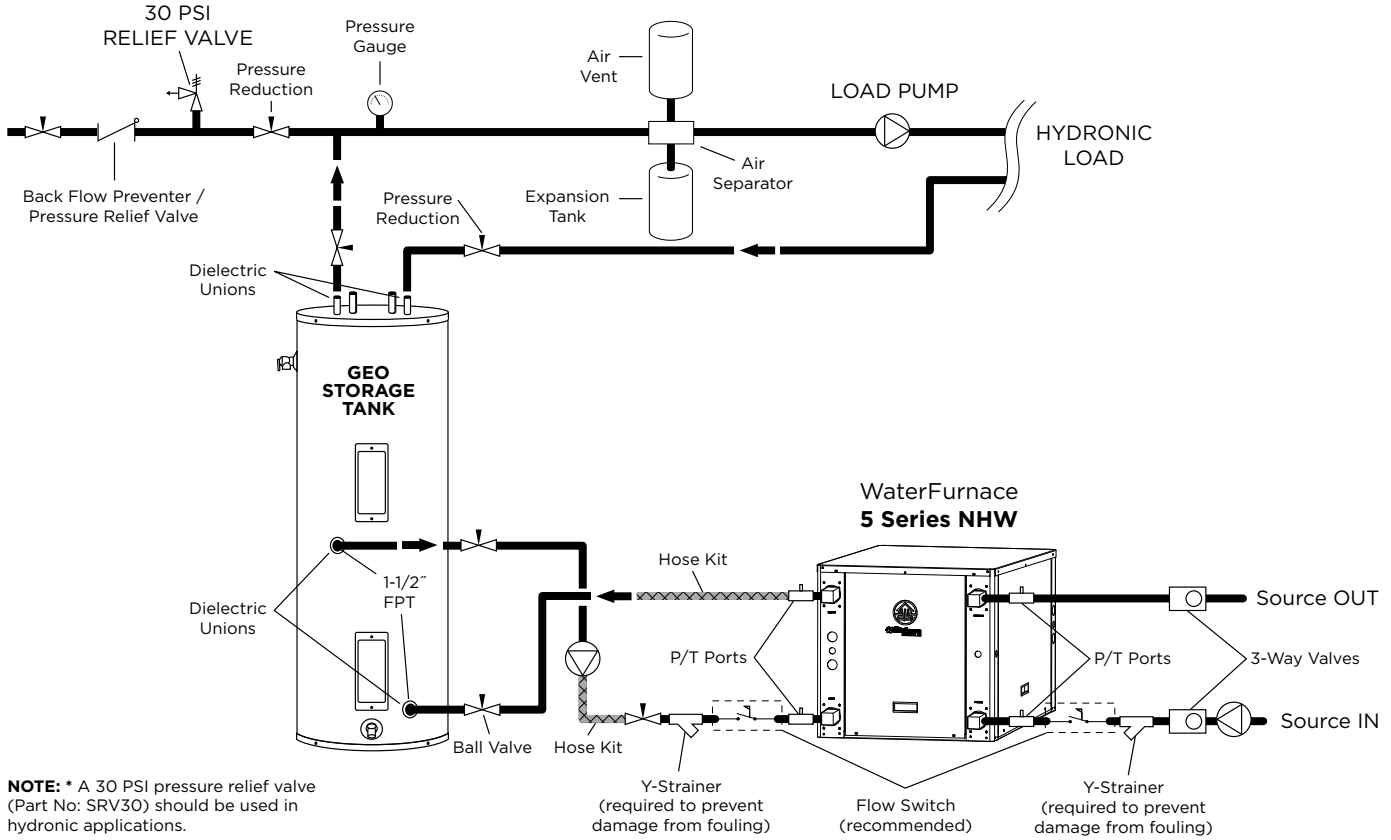

WARNING: When using a water storage tank thermostat the tank temperature should not be set higher than the maximum entering water temperature of the heat pump. This will limit the possibility of the heat pump from operating outside of the performance table.

Flow Rates

Load Flow Rate

The load flow on the 5 Series 502W12 should be 20 gpm (typically the rated flow). Refer to the table below. This flow rate is required especially when heating water to limit the effects of the higher condensing temperatures of water heating for radiant floor heating.

Model	Source Flow Rate (gpm)			Load Flow Rate (gpm)
	Minimum Open Loop	Open Loop < 50°F	Closed Loop Range (Min - Full Flow)	
NHW084	15	20	20 25	25

Source Flow Rate

The source flow can range between 15 and 25 gpm for earth loops. For open loop well water systems the minimum flow should be 15 gpm. In earth loop systems where entering water temperatures are expected to be above 95°F, 25 gpm should be used. In well systems where the water temperature is below 50°F, 20 gpm should be used to avoid nuisance freeze detection trips.

Water Quality

General

5 Series 502W12 systems may be successfully applied in a wide range of residential, commercial, and industrial applications. It is the responsibility of the system designer and installing contractor to ensure that acceptable water quality is present and that all applicable codes have been met in these installations.

Water Treatment

Do not use untreated or improperly treated water. Equipment damage may occur. The use of improperly treated or untreated water in this equipment may result in scaling, erosion, corrosion, algae or slime. The services of a qualified water treatment specialist should be engaged to determine what treatment, if any, is required. The product warranty specifically excludes liability for corrosion, erosion or deterioration of equipment.

The heat exchangers in the units are 316L stainless steel plates with copper brazing. The water piping in the heat exchanger is 304 stainless steel. There may be other materials in the building's piping system that the designer may need to take into consideration when deciding the parameters of the water quality.

If an antifreeze or water treatment solution is to be used, the designer should confirm it does not have a detrimental effect on the materials in the system.

Contaminated Water

In applications where the water quality cannot be held to prescribed limits, the use of a secondary or intermediate heat exchanger is recommended to separate the unit from the contaminated water.

The following table outlines the water quality guidelines for unit heat exchangers. If these conditions are exceeded, a secondary heat exchanger is required. Failure to supply a secondary heat exchanger where needed will result in a warranty exclusion for primary heat exchanger corrosion or failure.

Strainers

These units must have properly sized strainers upstream of both brazed plate heat exchangers to protect them against particles in the fluid. Failure to install proper strainers and perform regular service can result in serious damage to the unit, and cause degraded performance, reduced operating life and failed compressors. Improper installation of the unit (which includes not having proper strainers to protect the heat exchangers) can also result in voiding the warranty.

Field supplied strainers with 20-40 mesh (530-1060 microns) are recommended, with 30 mesh (800 microns) being the optimum choice. The strainers selected should have a mesh open area of at least 6 square inches (39 square centimeters) for each unit being serviced by the strainer. Using strainers with a smaller amount of open area will result in the need for more frequent cleaning.

Strainers should be selected on the basis of acceptable pressure drop, and not on pipe diameter. The strainers selected should have a pressure drop at the nominal flow rate of the units low enough to be within the pumping capacity of the pump being used.



WARNING: Must have intermediate heat exchanger when used in pool applications.

Water Quality Guidelines

Material		Copper	90/10 Cupronickel	316 Stainless Steel
pH	Acidity/Alkalinity	7 - 9	7 - 9	7 - 9
Scaling	Calcium and Magnesium Carbonate	(Total Hardness) less than 350 ppm	(Total Hardness) less than 350 ppm	(Total Hardness) less than 350 ppm
Corrosion	Hydrogen Sulfide	Less than 0.5 ppm (rotten egg smell appears at 0.5 ppm)	10 - 50 ppm	Less than 1 ppm
	Sulfates	Less than 125 ppm	Less than 125 ppm	Less than 200 ppm
	Chlorine	Less than 0.5 ppm	Less than 0.5 ppm	Less than 0.5 ppm
	Chlorides	Less than 20 ppm	Less than 125 ppm	Less than 300 ppm
	Carbon Dioxide	Less than 50 ppm	10 - 50 ppm	10 - 50 ppm
	Ammonia	Less than 2 ppm	Less than 2 ppm	Less than 20 ppm
	Ammonia Chloride	Less than 0.5 ppm	Less than 0.5 ppm	Less than 0.5 ppm
	Ammonia Nitrate	Less than 0.5 ppm	Less than 0.5 ppm	Less than 0.5 ppm
	Ammonia Hydroxide	Less than 0.5 ppm	Less than 0.5 ppm	Less than 0.5 ppm
	Ammonia Sulfate	Less than 0.5 ppm	Less than 0.5 ppm	Less than 0.5 ppm
	Total Dissolved Solids (TDS)	Less than 1000 ppm	1000 - 1500 ppm	1000 - 1500 ppm
	LSI Index	+0.5 to -0.5	+0.5 to -0.5	+0.5 to -0.5
Iron Fouling (Biological Growth)	Iron, FE ²⁺ (Ferrous) Bacterial Iron Potential	< 0.2 ppm	< 0.2 ppm	< 0.2 ppm
	Iron Oxide	Less than 1 ppm, above this level deposition will occur	Less than 1 ppm, above this level deposition will occur	Less than 1 ppm, above this level deposition will occur
Erosion	Suspended Solids	Less than 10 ppm and filtered for max. of 600 micron size	Less than 10 ppm and filtered for max. of 600 micron size	Less than 10 ppm and filtered for max. of 600 micron size
	Threshold Velocity (Fresh Water)	< 6 ft/sec	< 6 ft/sec	< 6 ft/sec

NOTES: Grains = ppm divided by 17 mg/L is equivalent to ppm

2/22/12

Dimensional Data

NHW084 - Top Waterline Configuration

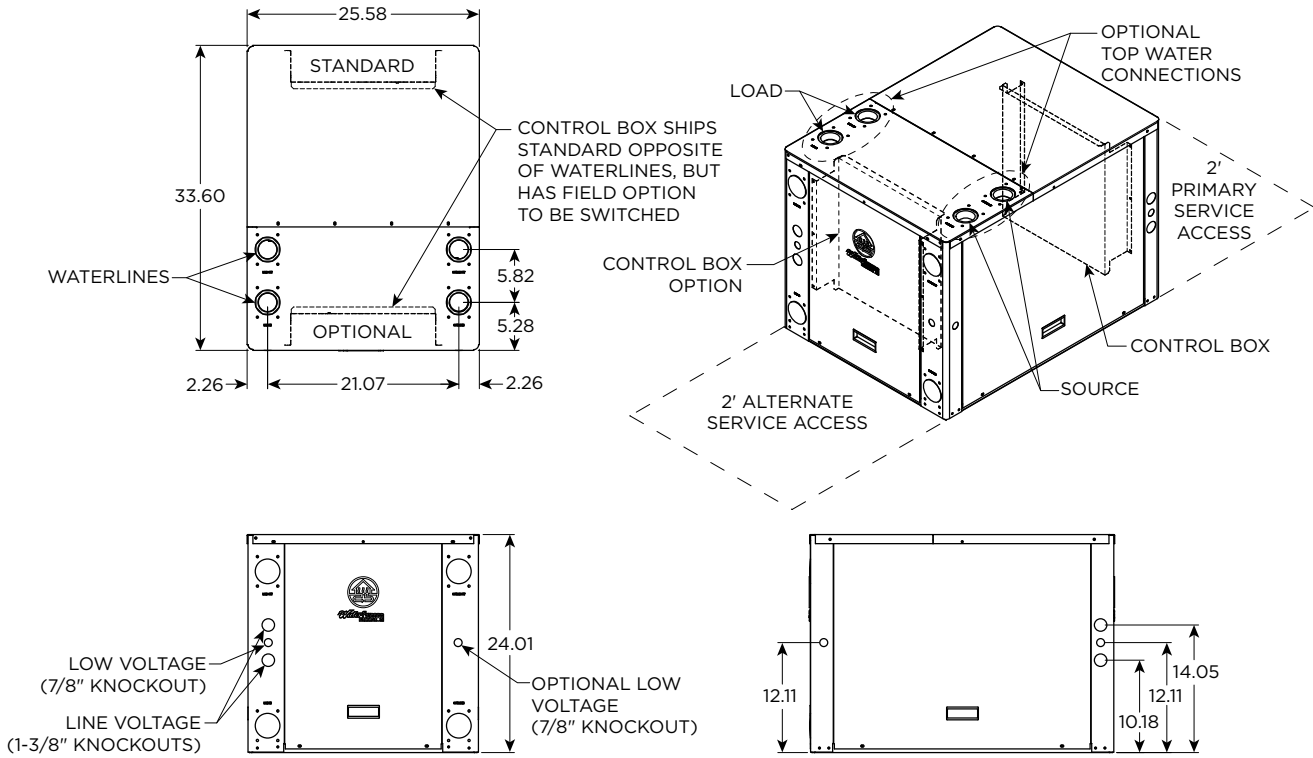

NHW084 - Back Waterline Configuration

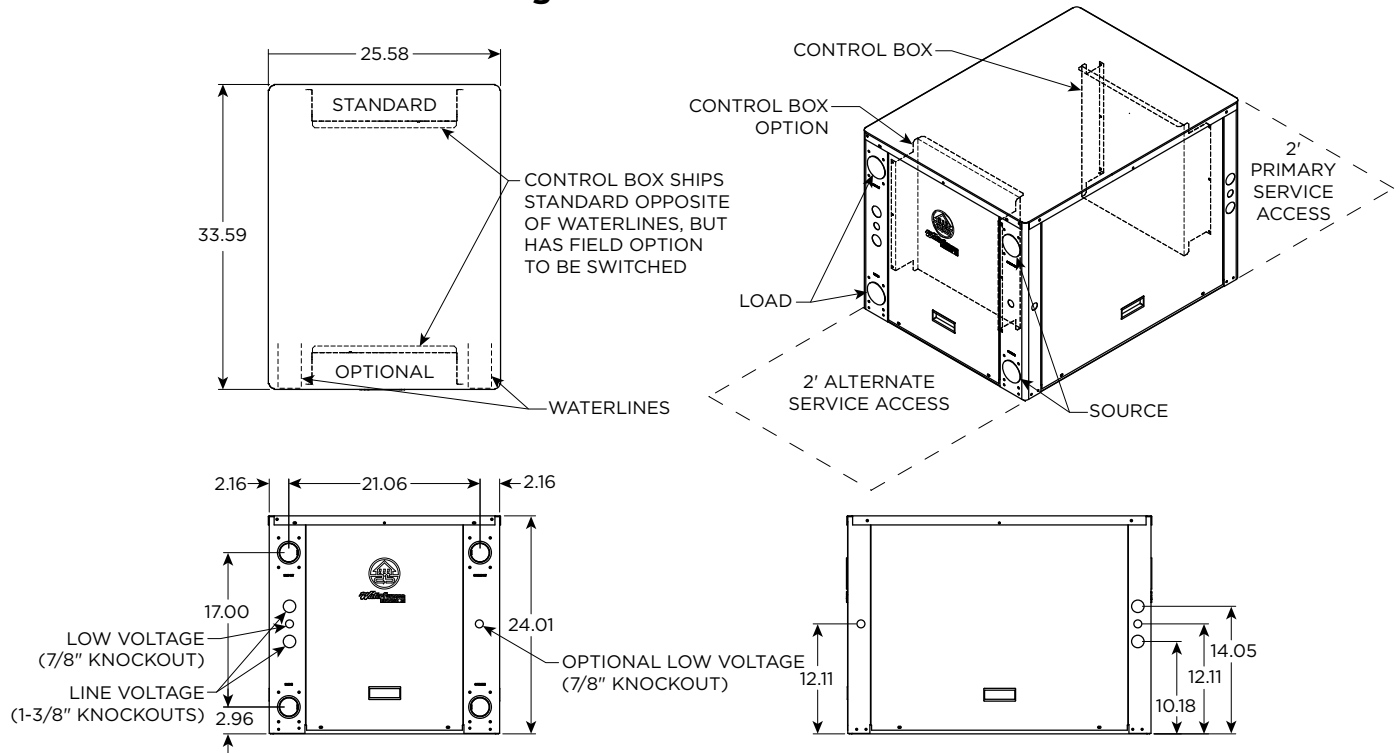

Physical Data

Model	084
Compressor (2 each)	Scroll
Factory Charge R-134a, oz [kg]	76 [2.16]
Load Water Connection	
FPT - in	1.25
Source Water Connection	
FPT - in	1.25
Weight - Operating, lb [kg]	420 [190]
Weight - Packaged, lb [kg]	415 [188]

2/14/12

Electrical Data

Model	Supply Circuit	Rated Voltage	Voltage Min/Max	Compressor*				Load Pump FLA	Source Pump FLA	Total Unit FLA	Min Circ Amp	Max Fuse/HACR
				MCC	RLA	LRA	LRA**					
084	L1/L2	208-230/60/1	187/253	37.0	23.7	144.0	65.0	-	-	23.7	29.6	50
	L3/L4	208-230/60/1	187/253	37.0	23.7	144.0	65.0	4.2	4.2	32.1	38.0	60

HACR circuit breaker in USA only

* Ratings per each compressor - unit supplied with two

** With optional IntelliStart

2/14/12

Reference Calculations

Heating Calculations: $LWT = EWT - \frac{HE}{\text{gpm} \times 500^*}$	Cooling Calculations: $LWT = EWT + \frac{HR}{\text{gpm} \times 500^*}$
---	---

NOTE: * When using water. Use 485 for 15% methanol/water or Environol solution.

Legend and Notes

ABBREVIATIONS AND DEFINITIONS:

COP = coefficient of performance (HC/kW x 3.413)
 EER = cooling energy efficiency (TC/kW)
 ELT = entering load fluid temperature to heat pump
 EST = entering source fluid temperature to heat pump
 ft HD = pressure drop in feet of head
 HC = heating capacity in MBtu/h
 HE = total heat of extraction, MBtu/h
 HR = total heat of rejection, MBtu/h
 kW = total power unit input, kilowatts

Lgpm = load flow in gallons per minute
 LLT = leaving load fluid temperature from heat pump
 LST = leaving source fluid temperature from heat pump
 LWPD = load heat exchanger water pressure drop
 psi = pressure drop in pounds per square inch
 Sgpm = source flow in gallons per minute
 SWPD = source heat exchanger water pressure drop
 TC = total cooling capacity in MBtu/h

Notes to Performance Data Tables

The following notes apply to all performance data tables:

- Three flow rates are shown for each unit. The lowest flow rate shown is used for geothermal open loop/well water systems with a minimum of 50°F EST. The middle flow rate shown is the minimum geothermal closed loop flow rate. The highest flow rate shown is optimum for geothermal closed loop systems and the suggested flow rate for boiler/tower applications.
- Leaving water temperatures below 40°F assumes 15% antifreeze solution.
- Interpolation between ELT, EST, and gpm data is permissible.
- Operation in the gray areas is not recommended.

Antifreeze Correction

Catalog performance can be corrected for antifreeze use. Please use the following table and note the example given.

Antifreeze Type	Antifreeze % by wt	Heating		Cooling		Pressure Drop
		Load	Source	Load	Source	
EWT - °F [°C]		90 [32.2]	30 [-1.1]	45 [7.2]	90 [32.2]	30 [-1.1]
Water	0	1.000	1.000	1.000	1.000	1.000
Ethylene Glycol	10	0.991	0.973	0.975	0.991	1.075
	20	0.979	0.943	0.946	0.979	1.163
	30	0.965	0.917	0.920	0.965	1.225
	40	0.955	0.890	0.895	0.955	1.324
	50	0.943	0.865	0.870	0.943	1.419
Propylene Glycol	10	0.981	0.958	0.959	0.981	1.130
	20	0.969	0.913	0.919	0.969	1.270
	30	0.950	0.854	0.866	0.950	1.433
	40	0.937	0.813	0.829	0.937	1.614
	50	0.922	0.770	0.789	0.922	1.816
Ethanol	10	0.991	0.927	0.941	0.991	1.242
	20	0.972	0.887	0.901	0.972	1.343
	30	0.947	0.856	0.866	0.947	1.383
	40	0.930	0.815	0.826	0.930	1.523
	50	0.911	0.779	0.791	0.911	1.639
Methanol	10	0.986	0.957	0.961	0.986	1.127
	20	0.970	0.924	0.928	0.970	1.197
	30	0.951	0.895	0.897	0.951	1.235
	40	0.936	0.863	0.865	0.936	1.323
	50	0.920	0.833	0.835	0.920	1.399

 **WARNING: Gray area represents antifreeze concentrations greater than 35% by weight and should be avoided due to the extreme performance penalty they represent.**

Antifreeze Correction Example

Antifreeze solution is propylene glycol 20% by weight for the source and methanol 10% for the load. Both source and load flow rates are 25 gpm. Determine the corrected heating at 30°F source and 80°F load as well as pressure drop at 30°F for a 5 Series NHW084. Also, determine the corrected cooling at 90°F source and 50°F load.

The corrected heating capacity at 30°F/80°F would be:

$$68,800 \text{ MBtu/h} \times 0.913 \times 0.985 = 61,872 \text{ MBtu/h}$$

The corrected cooling capacity at 90°F/50°F would be:

$$74,600 \times 0.969 \times 0.962 = 69,540 \text{ MBtu/h}$$

The corrected pressure drop at 30°F and 36 gpm would be:

$$3.4 \text{ psi} \times 1.270 = 4.32 \text{ psi}$$

Load and Source Pressure Drop

Model	gpm	Pressure Drop (psi)				
		30°F	50°F	70°F	90°F	110°F
084	15	1.6	1.5	1.4	1.2	1.2
	20	2.5	2.4	2.2	1.9	1.9
	25	3.4	3.2	3.1	2.6	2.6

2/14/12

NHW084 - Performance Data

Cooling Capacity

Source		ELT °F	Load Flow - 15 gpm						Load Flow - 20 gpm						Load Flow - 25 gpm						
EST °F	Flow gpm		LLT °F	HC MBtu/h	Power kW	HR MBtu/h	EER	LST °F	LLT °F	HC MBtu/h	Power kW	HR MBtu/h	EER	LST °F	LLT °F	HC MBtu/h	Power kW	HR MBtu/h	EER	LST °F	
30	15	50	38.7	84.6	3.3	95.7	25.9	42.8	41.5	85.1	3.3	96.3	26.0	39.6	43.1	85.7	3.3	96.9	26.0	37.8	
		70	58.6	85.7	3.2	96.7	26.6	42.9	61.4	86.0	3.2	97.1	26.7	39.7	63.1	86.4	3.2	97.4	26.7	37.8	
		90	78.4	86.8	3.2	97.7	27.4	43.0	81.3	87.0	3.2	97.8	27.4	39.8	83.0	87.1	3.2	98.0	27.4	37.8	
		110	98.3	88.0	3.1	98.7	28.2	43.2	101.2	87.9	3.1	98.6	28.1	39.9	103.0	87.9	3.1	98.6	28.1	37.9	
	20	50	39.1	81.6	3.2	92.5	25.5	42.3	41.8	81.8	3.2	92.7	25.5	39.3	43.4	81.9	3.2	92.9	25.5	37.4	
		70	58.9	83.0	3.2	93.8	26.2	42.5	61.5	85.0	3.2	96.0	26.4	39.6	63.0	87.0	3.3	98.2	26.7	37.9	
		90	78.7	84.4	3.1	95.0	27.0	42.7	81.4	86.3	3.2	97.1	27.2	39.7	82.9	88.3	3.2	99.2	27.4	37.9	
		110	98.6	85.8	3.1	96.3	27.8	42.8	101.4	85.9	3.1	96.4	27.8	39.6	103.1	86.0	3.1	96.5	27.9	37.7	
	25	50	39.5	78.6	3.1	89.4	25.0	41.9	42.2	78.4	3.1	89.2	25.0	38.9	43.7	78.2	3.1	88.9	24.9	37.1	
		70	59.3	80.3	3.1	90.9	25.8	42.1	61.6	84.0	3.2	94.9	26.2	39.5	63.0	87.7	3.3	98.9	26.6	37.9	
		90	79.1	81.9	3.1	92.4	26.7	42.3	81.4	85.6	3.2	96.4	27.1	39.6	82.8	89.4	3.3	100.5	27.5	38.0	
		110	98.9	83.6	3.0	93.9	27.5	42.5	101.6	83.8	3.0	94.2	27.6	39.4	103.3	84.0	3.0	94.4	27.7	37.6	
50	15	50	38.6	85.2	3.8	98.2	22.3	63.1	41.2	87.5	3.9	100.7	22.7	60.1	42.8	89.9	3.9	103.2	23.0	58.3	
		70	57.1	97.1	3.9	110.5	24.7	64.7	60.1	98.8	4.0	112.3	24.9	61.2	62.0	100.4	4.0	114.1	25.1	59.1	
		90	75.5	109.0	4.1	122.9	26.8	66.4	79.0	110.0	4.1	123.9	27.0	62.4	81.1	111.0	4.1	124.9	27.1	60.0	
		110	93.9	120.9	4.2	135.2	28.9	68.0	97.9	121.2	4.2	135.5	29.0	63.6	100.3	121.5	4.2	135.8	29.0	60.9	
	20	50	38.6	85.4	3.8	98.2	22.7	63.1	41.3	87.4	3.8	100.3	23.0	60.0	42.9	89.4	3.8	102.4	23.3	58.2	
		70	57.3	95.6	3.9	108.7	24.8	64.5	60.3	97.0	3.9	110.3	25.0	61.0	62.1	98.5	3.9	111.8	25.2	58.9	
		90	75.9	105.8	4.0	119.2	26.8	65.9	79.3	106.7	4.0	120.2	26.9	62.0	81.4	107.6	4.0	121.2	27.0	59.7	
		110	94.5	116.0	4.0	129.8	28.6	67.3	98.4	116.3	4.1	130.2	28.7	63.0	100.7	116.7	4.1	130.6	28.7	60.4	
	25	50	38.6	85.5	3.7	98.2	23.1	63.1	41.3	87.2	3.7	100.0	23.3	60.0	42.9	88.9	3.8	101.7	23.6	58.1	
		70	57.5	94.0	3.8	106.9	24.9	64.3	60.5	95.3	3.8	108.3	25.1	60.8	62.3	96.6	3.8	109.6	25.3	58.8	
		90	76.3	102.5	3.8	115.6	26.7	65.4	79.7	103.4	3.9	116.5	26.8	61.7	81.7	104.3	3.9	117.5	26.9	59.4	
		110	95.2	111.0	3.9	124.3	28.4	66.6	98.9	111.5	3.9	124.8	28.4	62.5	101.0	111.9	3.9	125.4	28.4	60.0	
70	15	50	38.6	85.8	4.5	101.4	18.9	83.5	41.2	88.1	4.5	103.5	19.4	80.4	42.8	90.3	4.5	105.7	20.0	78.5	
		70	55.9	105.4	4.8	121.7	22.1	86.2	59.2	107.6	4.8	123.8	22.6	82.4	61.2	109.8	4.7	126.0	23.2	80.1	
		90	73.3	125.0	5.0	142.1	25.0	88.9	77.3	127.2	5.0	144.1	25.6	84.4	79.7	129.3	5.0	146.2	26.1	81.7	
		110	90.7	144.6	5.2	162.4	27.7	91.7	95.3	146.7	5.2	164.5	28.2	86.4	98.1	148.8	5.2	166.5	28.7	83.3	
	20	50	38.5	86.0	4.5	101.3	19.2	83.5	41.2	88.1	4.5	103.3	19.7	80.3	42.8	90.1	4.4	105.2	20.3	78.4	
		70	56.1	104.2	4.7	120.1	22.3	86.0	59.4	106.1	4.6	122.0	22.8	82.2	61.4	108.1	4.6	123.9	23.4	79.9	
		90	73.7	122.3	4.9	138.9	25.2	88.5	77.6	124.2	4.8	140.7	25.7	84.1	79.9	126.1	4.8	142.6	26.2	81.4	
		110	91.3	140.5	5.0	157.6	27.9	91.0	95.8	142.3	5.0	159.4	28.3	85.9	98.5	144.2	5.0	161.2	28.8	82.9	
	25	50	38.5	86.2	4.4	101.3	19.5	83.5	41.2	88.0	4.4	103.0	20.1	80.3	42.8	89.9	4.4	104.8	20.6	78.4	
		70	56.3	102.9	4.6	118.5	22.5	85.8	59.5	104.7	4.5	120.2	23.0	82.0	61.5	106.4	4.5	121.8	23.6	79.7	
		90	74.1	119.6	4.7	135.7	25.4	88.1	77.9	121.3	4.7	137.3	25.8	83.7	80.2	123.0	4.7	138.9	26.3	81.1	
		110	91.8	136.3	4.9	152.9	28.0	90.4	96.2	137.9	4.8	154.4	28.5	85.4	98.8	139.5	4.8	156.0	28.9	82.5	
90	15	50	40.5	70.9	5.5	89.6	12.9	101.9	42.7	72.6	5.4	91.0	13.5	99.1	44.1	74.3	5.3	92.3	14.0	97.4	
		70	57.4	94.6	5.8	114.5	16.2	105.3	60.3	96.9	5.8	116.5	16.8	101.7	62.1	99.2	5.7	118.6	17.5	99.5	
		90	74.2	118.3	6.2	139.4	19.1	108.6	77.9	121.2	6.1	142.1	19.8	104.2	80.1	124.1	6.1	144.8	20.5	101.6	
		110	Operation not recommended.																		
	20	50	40.5	71.0	5.4	89.5	13.2	101.9	42.7	72.7	5.3	90.8	13.7	99.1	44.0	74.4	5.2	92.2	14.3	97.4	
		70	57.5	93.8	5.7	113.3	16.5	105.1	60.4	95.9	5.6	115.1	17.1	101.5	62.2	98.1	5.5	117.0	17.7	99.4	
		90	74.4	116.6	6.0	137.1	19.4	108.3	78.1	119.2	5.9	139.4	20.1	103.9	80.3	121.7	5.9	141.8	20.7	101.3	
		110	Operation not recommended.																		
	25	50	40.5	71.2	5.3	89.3	13.4	101.9	42.7	72.9	5.2	90.7	14.0	99.1	44.0	74.6	5.1	92.0	14.6	97.4	
		70	57.6	93.1	5.6	112.1	16.7	104.9	60.5	95.0	5.5	113.7	17.3	101.4	62.2	96.9	5.4	115.4	17.9	99.2	
		90	74.7	114.9	5.8	134.8	19.8	108.0	78.3	117.1	5.8	136.8	20.4	103.7	80.5	119.3	5.7	138.7	21.0	101.1	
		110	Operation not recommended.																		
110	15	50	41.4	64.8	6.7	87.8	9.6	121.7	43.4	66.2	6.8	89.4	9.7	118.9	44.6	67.6	6.8	90.9	9.9	117.3	
		70	57.4	94.8	7.2	119.5	13.1	125.9	60.3	97.4	7.3	122.4	13.3	122.2	62.0	100.1	7.4	125.4	13.5	120.0	
		90	Operation not recommended.																		
		110	Operation not recommended.																		
	20	50	41.3	65.0	6.6	87.6	9.8	121.7	43.3	66.5	6.7	89.3	10.0	118.9	44.6	68.1	6.7	91.0	10.1	117.3	
		70	57.4	94.4	7.1	118.5	13.4	125.8	60.3	96.9	7.2	121.3	13.5	122.1	62.1	99.3	7.2	124.0	13.7	119.9	
		90	Operation not recommended.																		
		110	Operation not recommended.																		
	25	50	41.3	65.1	6.5	87.4	10.0	121.7	43.3	66.8	6.6	89.2	10.2	118.9	44.5	68.5	6.6	91.1	10.4	117.3	
		70	57.5	94.0	6.9	117.5	13.6	125.7	60.4	96.3	7.0	120.1	13.8	122.0	62.1	98.6	7.0	122.6	14.0	119.8	
		90	Operation not recommended.																		
		110	Operation not recommended.																		

NHW084 - Performance Data cont.

Heating Capacity

Source		ELT °F	Load Flow - 15 gpm					Load Flow - 20 gpm					Load Flow - 25 gpm								
EST °F	Flow gpm		LLT °F	HC MBtu/h	Power kW	HE MBtu/h	COP	LST °F	LLT °F	HC MBtu/h	Power kW	HE MBtu/h	COP	LST °F	LLT °F	HC MBtu/h	Power kW	HE MBtu/h	COP	LST °F	
30	15	60	69.1	68.1	3.8	55.1	5.2	22.7	66.8	67.7	3.8	54.8	5.3	24.5	65.4	67.3	3.7	54.6	5.3	22.7	
		80	88.8	66.3	5.0	49.3	3.9	23.4	86.6	65.9	5.1	48.6	3.8	25.1	85.2	65.5	5.2	47.8	3.7	23.6	
		100	108.6	64.5	6.2	43.5	3.1	24.2	106.4	64.1	6.4	42.3	2.9	25.8	105.1	63.6	6.6	41.1	2.8	24.5	
		120	128.4	62.7	7.3	37.7	2.5	25.0	126.2	62.2	7.3	37.3	2.5	26.3	124.9	61.8	7.3	37.0	2.5	25.1	
	140	148.1	61.0	8.5	31.9	2.1	25.7	146.0	60.4	8.4	31.7	2.1	26.8	144.8	59.9	8.3	31.5	2.1	25.8		
	20	60	69.3	70.1	3.8	57.0	5.4	24.3	67.0	69.7	3.8	56.8	5.4	24.3	65.5	69.3	3.7	56.5	5.4	24.3	
		80	89.1	68.0	5.0	50.9	4.0	24.9	86.8	67.6	5.0	50.4	3.9	25.0	85.4	67.1	5.0	49.9	3.9	25.0	
		100	108.8	66.0	6.2	44.9	3.1	25.5	106.5	65.5	6.3	44.1	3.1	25.6	105.2	64.9	6.3	43.3	3.0	25.7	
		120	128.5	64.0	7.4	38.8	2.5	26.1	126.3	63.3	7.3	38.4	2.5	26.2	125.0	62.7	7.2	38.0	2.5	26.2	
	140	148.3	61.9	8.6	32.7	2.1	26.7	146.1	61.2	8.5	32.4	2.1	26.8	144.8	60.5	8.4	32.0	2.1	26.8		
	25	60	69.6	72.1	3.9	58.9	5.5	25.3	67.2	71.7	3.8	58.7	5.5	24.1	65.7	71.3	3.8	58.5	5.6	25.3	
		80	89.3	69.8	5.0	52.6	4.1	25.8	86.9	69.3	5.0	52.3	4.1	24.8	85.5	68.8	4.9	52.0	4.1	25.8	
100		109.0	67.5	6.2	46.3	3.2	26.3	106.7	66.9	6.1	45.9	3.2	25.4	105.3	66.2	6.1	45.5	3.2	26.4		
120		128.7	65.2	7.4	39.9	2.6	26.8	126.4	64.4	7.3	39.5	2.6	26.1	125.1	63.6	7.2	39.0	2.6	26.9		
140	148.4	62.9	8.6	33.6	2.1	27.3	146.2	62.0	8.5	33.0	2.1	26.7	144.9	61.1	8.4	32.5	2.1	27.4			
50	15	60	72.6	94.2	4.2	80.1	6.7	39.3	69.3	92.9	4.1	79.0	6.7	42.1	67.3	91.6	4.0	77.9	6.7	39.6	
		80	92.3	92.1	5.4	73.7	5.0	40.2	89.1	91.0	5.4	72.6	4.9	42.7	87.2	89.9	5.4	71.5	4.9	40.5	
		100	112.0	90.0	6.7	67.3	4.0	41.0	108.9	89.2	6.7	66.2	3.9	43.4	107.1	88.3	6.8	65.1	3.8	41.3	
		120	131.7	87.9	7.9	60.9	3.3	41.9	128.7	87.3	7.8	60.7	3.3	43.9	126.9	86.7	7.7	60.5	3.3	41.9	
	140	151.4	85.8	9.2	54.6	2.7	42.7	148.5	85.4	9.0	54.8	2.8	44.5	146.8	85.1	8.8	55.0	2.8	42.7		
	20	60	72.8	95.8	4.2	81.6	6.7	41.8	69.4	94.4	4.1	80.4	6.8	42.0	67.4	92.9	4.0	79.2	6.8	42.1	
		80	92.5	93.8	5.4	75.3	5.1	42.5	89.3	92.6	5.4	74.3	5.1	42.6	87.3	91.5	5.3	73.3	5.0	42.7	
		100	112.2	91.8	6.7	69.0	4.0	43.1	109.1	90.9	6.7	68.1	4.0	43.2	107.2	90.0	6.6	67.3	4.0	43.3	
		120	132.0	89.8	7.9	62.7	3.3	43.7	128.9	89.1	7.8	62.4	3.3	43.8	127.1	88.5	7.7	62.2	3.4	43.8	
	140	151.7	87.8	9.2	56.4	2.8	44.4	148.7	87.4	9.0	56.5	2.8	44.3	147.0	87.0	8.9	56.7	2.9	44.3		
	25	60	73.0	97.4	4.2	83.1	6.8	43.3	69.6	95.8	4.1	81.9	6.9	41.8	67.5	94.3	4.0	80.6	6.9	43.6	
		80	92.7	95.4	5.4	76.9	5.1	43.8	89.4	94.2	5.3	76.0	5.2	42.4	87.4	93.0	5.2	75.1	5.2	44.0	
100		112.5	93.5	6.7	70.6	4.1	44.3	109.3	92.6	6.6	70.1	4.1	43.0	107.3	91.6	6.5	69.5	4.1	44.4		
120		132.2	91.6	8.0	64.4	3.4	44.8	129.1	90.9	7.8	64.2	3.4	43.6	127.2	90.2	7.7	64.0	3.4	44.9		
140	152.0	89.7	9.3	58.1	2.8	45.3	148.9	89.3	9.1	58.3	2.9	44.2	147.1	88.8	8.9	58.4	2.9	45.3			
70	15	60	76.1	120.4	4.5	105.1	7.8	56.0	71.8	118.1	4.4	103.1	7.9	59.7	69.3	115.8	4.3	101.2	7.9	56.5	
		80	95.7	118.0	5.8	98.1	5.9	56.9	91.6	116.2	5.7	96.6	5.9	60.3	89.2	114.4	5.6	95.2	5.9	57.3	
		100	115.4	115.5	7.1	91.2	4.7	57.8	111.4	114.3	7.1	90.2	4.7	61.0	109.0	113.0	7.0	89.2	4.7	58.1	
		120	135.1	113.1	8.5	84.2	3.9	58.8	131.2	112.4	8.3	84.1	4.0	61.6	128.9	111.7	8.1	84.0	4.0	58.8	
	140	154.8	110.6	9.8	77.2	3.3	59.7	151.0	110.4	9.6	77.8	3.4	62.2	148.8	110.3	9.3	78.4	3.5	59.5		
	20	60	76.2	121.5	4.5	106.2	7.9	59.4	71.9	119.1	4.4	104.1	7.9	59.6	69.3	116.6	4.3	101.9	8.0	59.8	
		80	95.9	119.5	5.8	99.6	6.0	60.0	91.8	117.7	5.7	98.1	6.0	60.2	89.3	115.8	5.6	96.6	6.0	60.3	
		100	115.7	117.5	7.2	93.1	4.8	60.7	111.6	116.3	7.1	92.2	4.8	60.8	109.2	115.0	6.9	91.3	4.9	60.9	
		120	135.4	115.6	8.5	86.5	4.0	61.3	131.5	114.9	8.3	86.5	4.0	61.3	129.1	114.2	8.1	86.5	4.1	61.4	
	140	155.1	113.6	9.8	80.0	3.4	62.0	151.3	113.5	9.6	80.7	3.5	61.9	149.1	113.4	9.4	81.4	3.5	61.9		
	25	60	76.4	122.6	4.5	107.3	8.0	61.4	72.0	120.0	4.4	105.0	8.0	59.5	69.4	117.3	4.3	102.7	8.0	61.8	
		80	96.1	121.1	5.8	101.2	6.1	61.9	91.9	119.1	5.7	99.6	6.1	60.0	89.4	117.2	5.6	98.1	6.1	62.2	
100		115.9	119.6	7.2	95.0	4.9	62.4	111.8	118.3	7.0	94.3	4.9	60.6	109.4	117.0	6.9	93.5	5.0	62.5		
120		135.7	118.0	8.6	88.8	4.0	62.9	131.7	117.4	8.4	88.9	4.1	61.1	129.3	116.8	8.2	89.0	4.2	62.9		
140	155.5	116.5	9.9	82.7	3.4	63.4	151.7	116.6	9.7	83.5	3.5	61.6	149.3	116.6	9.4	84.4	3.6	63.2			
90	15	60	79.5	146.6	4.8	130.0	8.9	72.7	74.3	143.3	4.7	127.3	8.9	77.3	71.2	140.1	4.6	124.5	9.0	73.4	
		80	99.2	143.8	6.2	122.5	6.8	73.7	94.1	141.4	6.1	120.7	6.8	77.9	91.1	138.9	5.9	118.8	6.9	74.2	
		100	118.8	141.0	7.6	115.0	5.4	74.7	113.9	139.4	7.4	114.1	5.5	78.6	111.0	137.8	7.2	113.2	5.6	74.9	
		120	138.4	138.2	9.0	107.5	4.5	75.7	133.7	137.4	8.8	107.5	4.6	79.3	130.9	136.6	8.5	107.5	4.7	75.7	
	140	Operation not recommended.																			
	20	60	79.6	147.2	4.8	130.8	8.9	76.9	74.4	143.7	4.7	127.7	9.0	77.2	71.2	140.2	4.6	124.6	9.0	77.5	
		80	99.4	145.3	6.2	124.0	6.8	77.6	94.3	142.7	6.1	122.0	6.9	77.8	91.2	140.1	5.9	120.0	7.0	78.0	
		100	119.1	143.3	7.7	117.2	5.5	78.3	114.2	141.7	7.4	116.3	5.6	78.4	111.2	140.1	7.2	115.4	5.7	78.5	
		120	138.8	141.3	9.1	110.4	4.6	79.0	134.1	140.7	8.8	110.6	4.7	78.9	131.2	140.0	8.6	110.7	4.8	78.9	
	140	Operation not recommended.																			
	25	60	99.6	146.8	6.2	125.5	6.9	80.0	94.4	144.1	6.1	123.3	6.9	77.7	91.3	141.3	5.9	121.1	7.0	80.3	
		80	119.4	145.6	7.7	119.4	5.6	80.4	114.4	144.0	7.5	118.5	5.6	78.2	111.4	142.4	7.3	117.5	5.7	80.6	
100		139.3	144.5	9.1	113.3	4.6	80.9	134.4	143.9	8.9	113.6	4.8	78.6	131.5	143.4	8.6	113.9	4.9	80.9		
120		154.1	143.6	10.2	108.7	4.1	81.3	149.4	143.8	9.9	110.0	4.2	79.0	146.5	144.1	9.6	111.2	4.4	81.1		
140	Operation not recommended.																				

Wiring Schematics

MUI Wiring Diagram

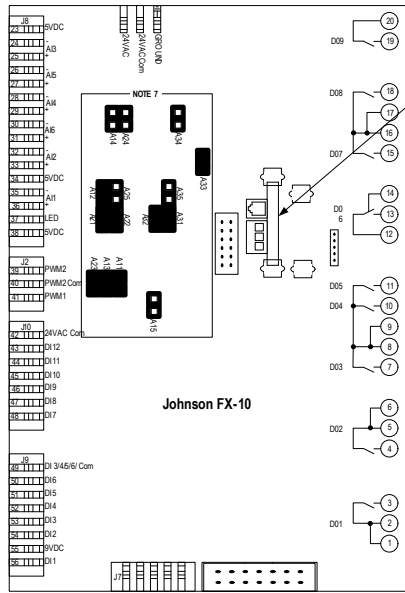

DLI Card

Instructions :

- 1.) Disconnect all power sources to the unit
- 2.) Remove MUI from Back Plate
- 3.) Follow Wiring Instruction Below
- 4.) Reinstall MUI to Back Plate

MUI Back Plate

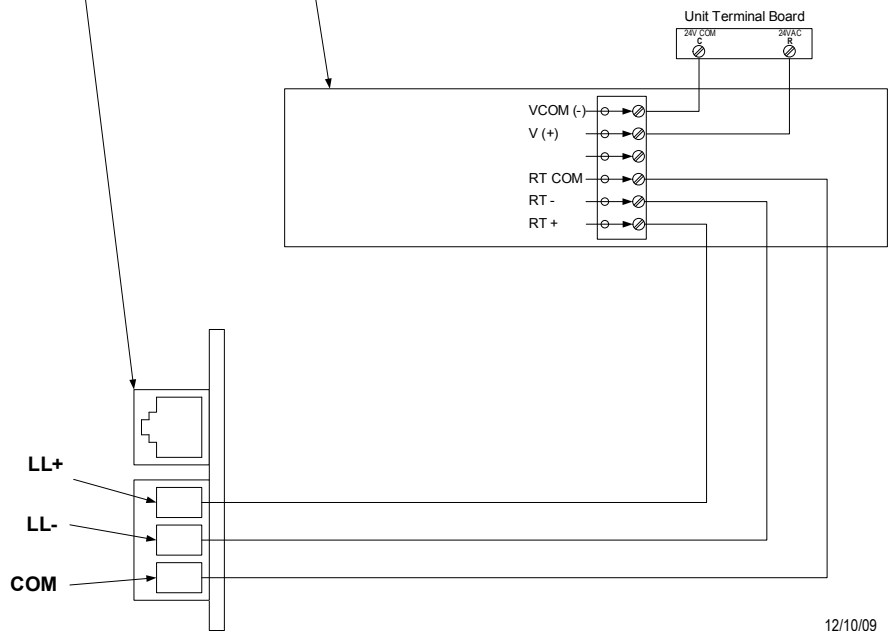

12/10/09

Wiring Schematics cont.

208-230/60/1

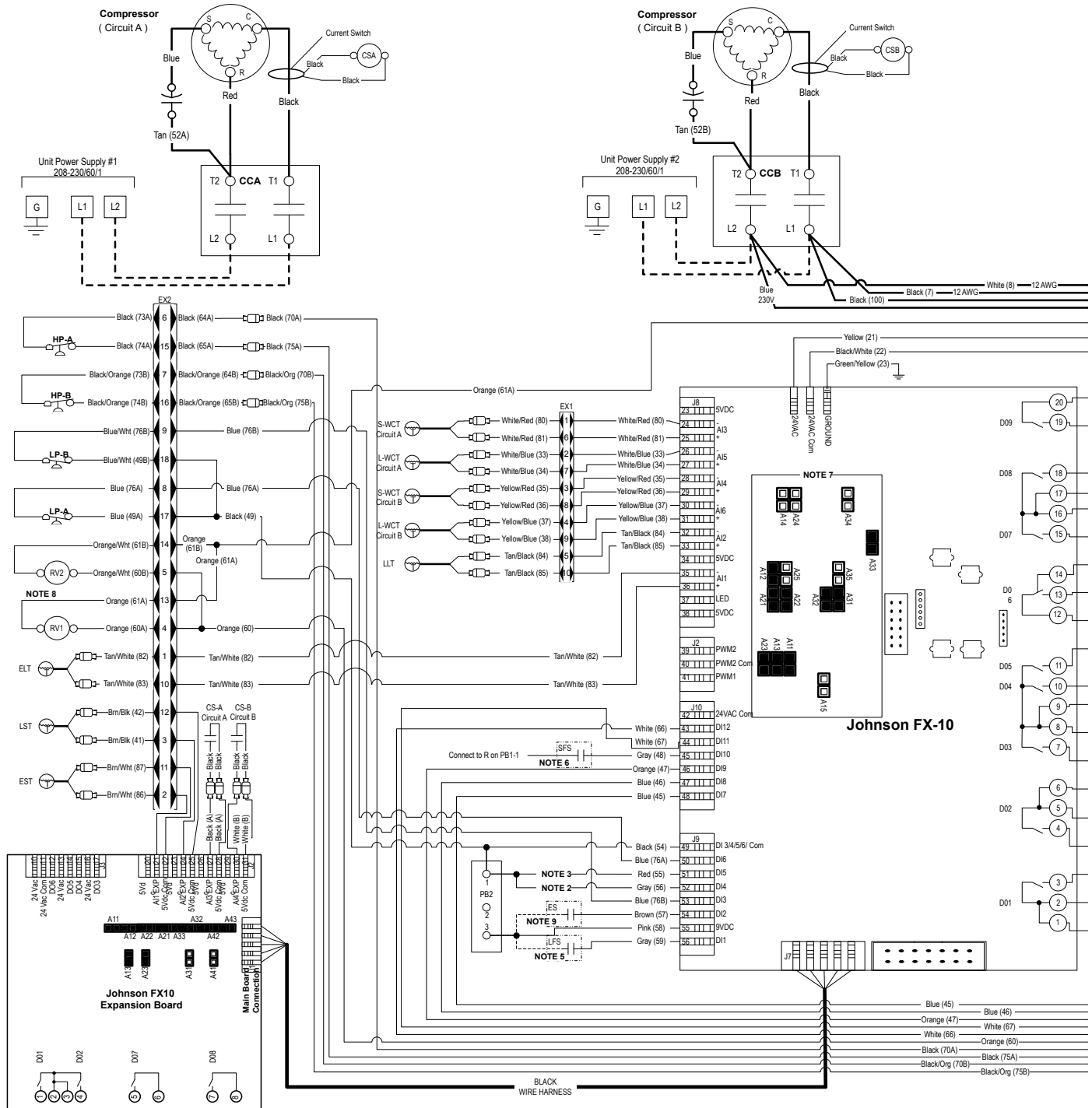

Wiring Schematics cont.

208-230/60/1 with IntelliStart

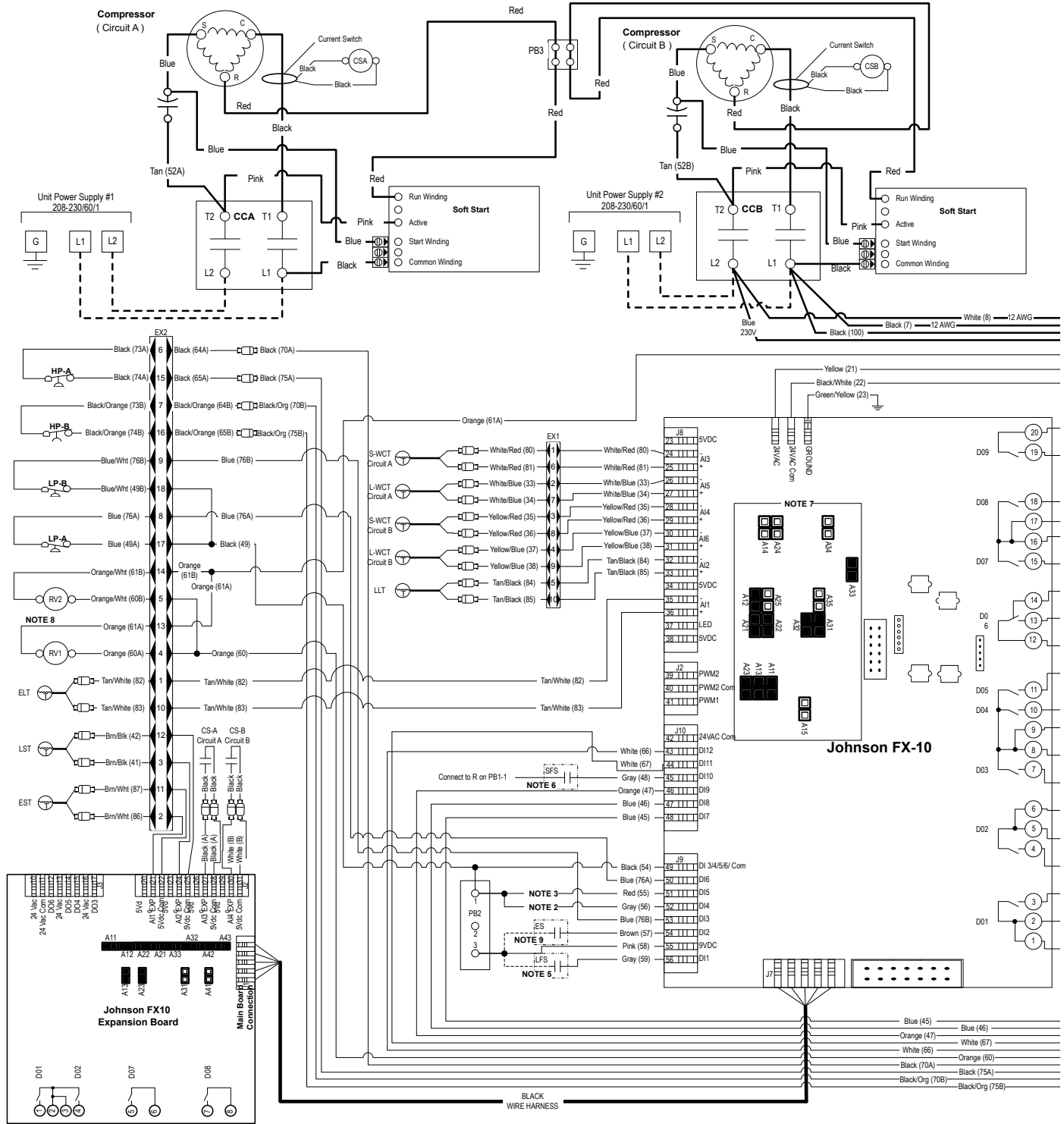

Accessories and Options

Flow Proving Switch

The FPS300 flow switch is designed to detect the presence or absence of flow in the piping of a water source heat pump. In water source heat pumps the flow switch is normally used to shut off the compressor whenever there is not circulation of the brine solution through the braze plate or coaxial heat exchanger. A lack of circulation can damage braze plate or coaxial heat exchangers if freezing occurs.



Load and Source Piping Connections

The 5 Series 502W12 has three connection options available. Each kit is intended to connect one piping connection. Therefore, two kits will be required for each unit. The kits can be mixed for installer convenience, one on source and the other on load.

- **CK5L** - Kit includes a pair of forged brass street elbows (1-1/4 in. MPT x 1-1/4 in. hose barb) with 1/4 in. pressure/temperature plugs
- **CK5L-XL** - 1-1/4 in. rubber hose kit includes CK5L plus two 8 ft. pieces of 1-1/4 in. rubber hose, a pair of 1-1/4 in. hose barb x 1-1/4 in. XL style fittings, and steel hose clamps
- **CK5L-XLS** - 1-1/4 in. rubber hose kit includes all the same items from CK5L-XL plus 1-1/4 in. 20 mesh bronze strainer



WARNING: All field installed piping and piping connections must be rated for temperatures greater than 160°F. Materials such as PVC, CPVC, and DWV shall not be used.

Strainers

All units shall have a field-installed 1-1/4 in. Y-strainer with a self-aligning screen and blow-off port to reduce debris that will enter the condenser/evaporator. Strainers should be made of a brass body with a 316 stainless steel 20-40 mesh screen.



WARNING: Warranty is void if strainers are not used on the entering side of the load and source.

Earth Loop and Load-side Pump Kits (Field Installed)

A specially designed one or two-pump module provides all liquid flow, fill and connection requirements for independent single unit systems (230/60/1 only).

Calculate the system pressure drop then refer to the pump curves to select the proper pump. All of the WaterFurnace pump kits can be used for hydronic heating applications as long as they meet the flow requirements. If the flow requirements are outside the pump curve, an alternate pump will need to be obtained to maintain the necessary flow.

PML32-160 - UPS32-160 without valves, cast iron pump volute, 3-speed, 2 in. FPT adapters included

PML40-160 - UPS40-160 without valves, cast iron pump volute, 3-speed, 2 in. FPT adapters included

PML40-240 - UPS40-240 without valves, cast iron pump volute, 3-speed, 2 in. FPT adapters included

FCM2-3023 - UPS60-150 (x2) with valves, cast iron pump volute, 3-speed, 2 in. Flo-Link XL connections

FCL1-5028 - UPS32-160 with valves, cast iron pump volute, 3-speed, 2 in. Flo-Link XL connections

FCL1-5038 - UPS40-160 with valves, cast iron pump volute, 3-speed, 2 in. Flo-Link XL connections

FCL1-5055 - FCL1-5055 - UPS40-240 with valves, cast iron pump volute, 3-speed, 2 in. Flo-Link XL connections

HydroZone Tank Controller

Tank controller (**HZC**) that adds outdoor reset with warm weather shutdown, setpoint control, process control, and management of four compressor outputs for our water-to-water systems.

HZAB

This is used in conjunction with the HydroZone to control the Geo-Storage tank electric heating element.

Accessories and Options cont.

Pump Curve - FCM2-3023

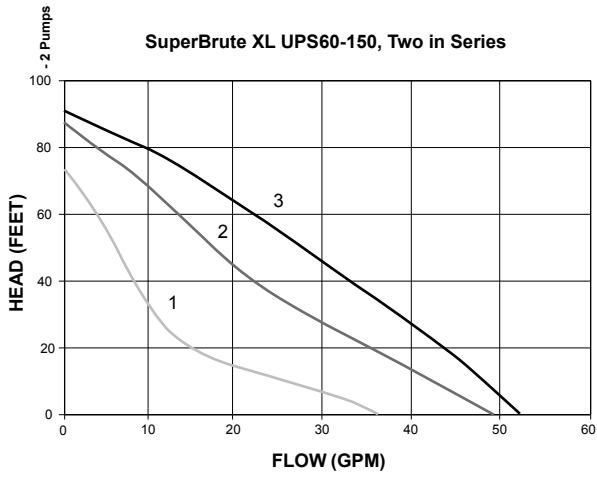

Pump Curve - FCL1-5028

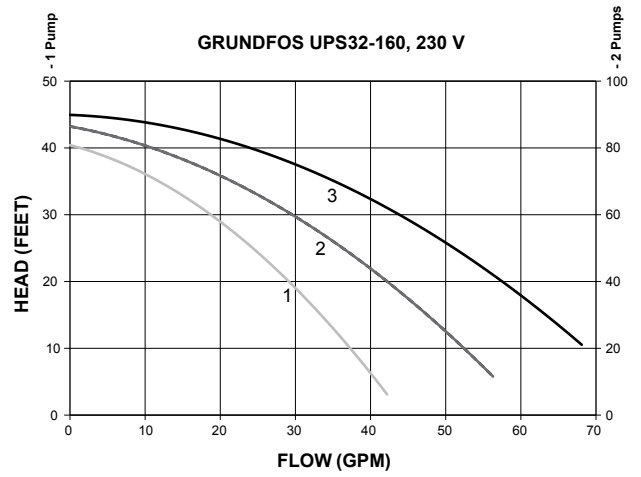

Pump Curve - FCL1-5038

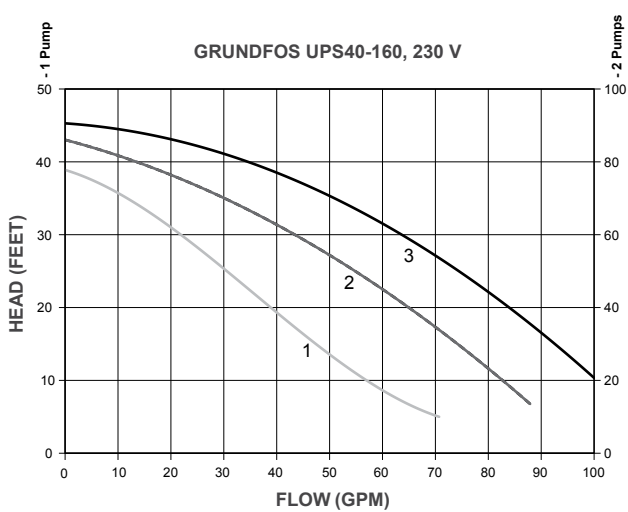

Pump Curve - FCL1-5055

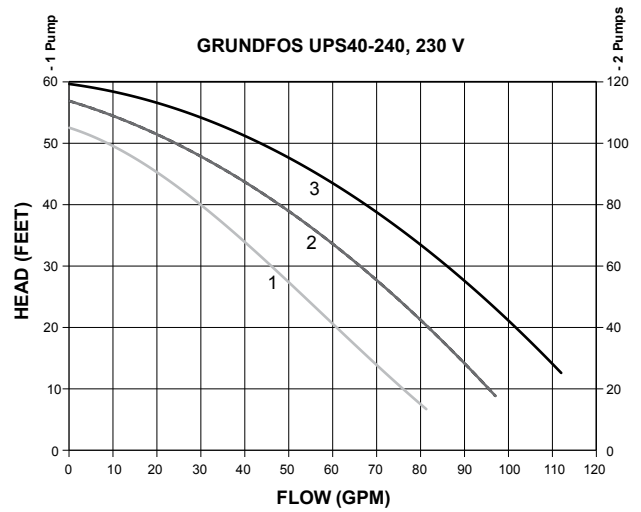

Accessories and Options cont.

Geothermal Storage Tank

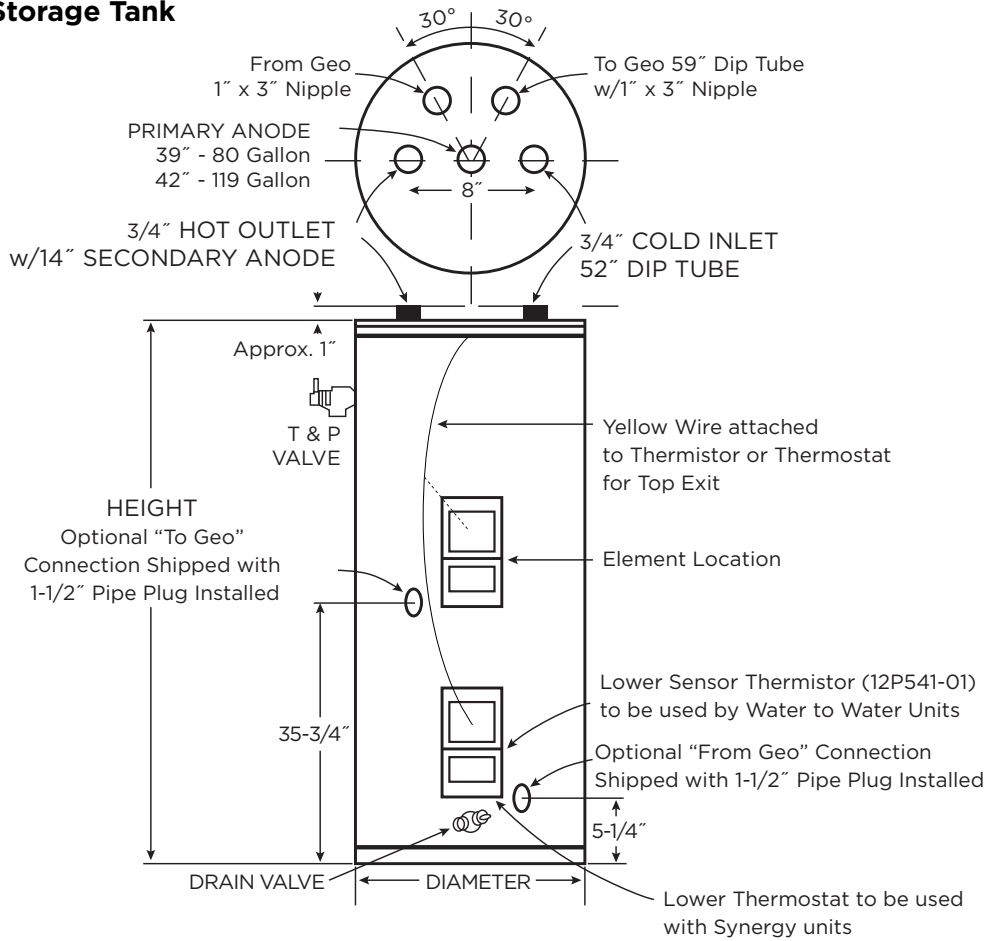

MODEL NUMBER	GALLON CAPACITY	ELEMENT WATTAGE (240 VOLT)	NUMBER OF ELEMENTS	R VALUE	DIMENSIONS IN INCHES		APPROX. SHIPPING WEIGHT (lbs.)
					HEIGHT	DIAMETER	
GEO-STORAGE-80	80	4500	1	16	63-1/4	24	204
GEO-STORAGE-120	119	4500	1	16	63-1/4	28	311

Engineering Guide Specifications

General

The liquid source water-to-water heat pump shall be a single packaged option heating/cooling unit. The unit shall be listed by a nationally recognized safety-testing laboratory or agency, such as ETL Testing Laboratory, Underwriters Laboratory (UL), or Canadian Standards Association (CSA). The unit shall be rated in accordance with Air Conditioning, Heating, and Refrigeration Institute/International Standards Organization (AHRI/ISO) and Canadian Standards Association (CSA-US). The liquid source water-to-water heat pump unit, as manufactured by WaterFurnace International, Fort Wayne, Indiana, shall be designed to operate with source liquid temperatures between 30°F [1.1°C] and 110°F [43.3°C] in cooling, and between 30°F [-1.1°C] and 90°F [32.2°C] in heating.

Casing and Cabinet

The cabinet shall be fabricated from heavy-gauge galvanized steel and finished with corrosion-resistant powder coating. This corrosion protection system shall meet the stringent 1,000 hour salt spray test per ASTM B117. The interior shall be insulated with 1/2 in. thick, multi-density, coated glass fiber for noise suppression.

The control box shall have separate holes and knockouts for entrance of line voltage and low voltage control wiring. All factory-installed wiring passing through factory knockouts and openings shall be protected from sheet metal edges at openings by plastic ferrules. The control box shall be field switchable from front to back for improved application flexibility with quick attach low voltage harnesses. The control box is shipped standard on the opposite end of the water connections.

Refrigerant Circuit

All units shall contain two (2) sealed refrigerant circuits, each containing a hermetic motor scroll compressor, discharge muffler, bidirectional thermal expansion valve assemblies, optional reversing valve, braze plate heat exchangers, factory installed high and low pressure safety switches, freeze detection, service ports, and liquid line filter driers. Compressors shall be scroll types designed for heat pump duty with internal isolation and mounted on rubber vibration isolators. Compressor motors shall have internal overload protection. A high density sound attenuating blanket shall be factory installed around the compressor to reduce sound. Discharge mufflers shall be included to help quiet compressor discharge gas pulsations. The water-to-refrigerant heat exchangers shall be interlaced copper brazed, 316 stainless plate steel, capable of withstanding 450 psig [3108 kPa] working

pressure on the refrigerant side and 450 psig [3108 kPa] on the water side. The thermal expansion valve assembly shall provide proper superheat over the liquid temperature range with minimal "hunting." The assembly shall operate bidirectionally without the use of check valves for the reversible option. Externally mounted pressure controlled water regulating flow valves are not acceptable.

Piping and Connections

Supply and return water connections shall be 1-1/4 in. [31.8 mm] FPT copper fittings fixed to the cabinet by use of a captive fitting, which eliminates the need for backup pipe wrenches.

Optional Back/Top Mount Water Connections - shall be factory installed to the back corner post or top panel by use of a captive fitting, which eliminates the need for backup pipe wrenches.



WARNING: Warranty is void if strainers are not used on the entering side of the load and source.



WARNING: All field installed piping and piping connections must be rated for temperatures greater than 160°F. Materials such as PVC, CPVC, and DWV shall not be used.

Electrical

Controls and safety devices will be factory wired and mounted within the unit. Controls shall include 24 Volt activated compressor contactors, 24VAC-75VA transformer with built in circuit breaker, reversing valve coils, and anti short-cycle protection. A terminal block with screw in terminals will be provided for field control wiring. To prevent short cycling when the safety controls are activated, the reset relay shall provide a lockout circuit that requires resetting of low voltage supply or main circuit breaker. A lockout signal shall be provided to the display to indicate a lockout situation. Units shall be name-plated for use with time delay fuses or HACR circuit breakers. Unit controls shall be 24 Volt and provide heating or cooling as required by the remote thermostat/sensor.

Optional IntelliStart (Compressor Soft Starter) - shall be factory installed for use in applications that require low starting amps, reduced compressor startup noise, off-grid, and improved startup behavior. IntelliStart shall reduce normal starting current by 60% on 208-230/60/1 units.

Engineering Guide Specifications cont.

Microprocessor Control

The unit shall be controlled using an FX10 microprocessor which sequences all functions and modes of operations. The control shall interface with a (Y,B) thermostat, mechanical or electronic. The control system shall have the following features:

1. Anti-short cycle time delay on compressor operation, time delay shall be a minimum of four minutes
2. Random start on power up mode
3. Low voltage protection
4. High voltage protection
5. Unit shutdown on high or low refrigerant pressures
6. Unit shutdown for low water temperature
7. Source and Load heat exchanger low water temperature cutout selectable for water or anti-freeze
8. Automatic intelligent reset (Unit will automatically reset 5 minutes after trip if the fault has cleared. Should a fault reoccur 3 times sequentially then permanent lockout will occur.)
9. A 4 x 20 digit backlit LCD to display the following:
 - a. Entering and leaving water temperatures
 - b. High pressure, low pressure, low voltage, high voltage, low water temperature cutout, and control status
10. The low pressure shall not be monitored for the first 120 seconds after a compressor start command to prevent nuisance safety trips.
11. Remote fault indication on the thermostat
12. An accessory relay output tied to each compressor selectable for normally open or normally closed

Accessories

Flow Proving Switch

WaterFurnace P/N - FPS300

A flow proving switch shall be available utilizing high reliability flow sensing technology.

Connection Kit

WaterFurnace P/N - CK5L

Kit includes a pair of forged brass street elbows (1-1/4 in. MPT x 1-1/4 in. hose barb) with 1/4 in. pressure/temperature plugs

Rubber Hose Kit Set

WaterFurnace P/N - CK5L-XL

1-1/4 in. rubber hose kit includes CK5L plus two 8 ft. pieces of 1-1/4 in. rubber hose, a pair of 1-1/4 in. hose barb x 1-1/4 in. XL style fittings, and steel hose clamps

Strainer Hose Kit Set

WaterFurnace P/N - CK5L-XLS

1-1/4 in. rubber hose kit includes all the same items from CK5L-XL plus 1-1/4 in. 20 mesh bronze strainer



Manufactured by
WaterFurnace International, Inc.
9000 Conservation Way
Fort Wayne, IN 46809
www.waterfurnace.com

